



# SECTION 6 - DRIVE SYSTEM

## TABLE OF CONTENTS

Drive System ..... 6-2

General Information..... 6-2

Front Drive Actuator (400 FIS/500/650 H1/  
650 V-Twin)..... 6-3

Front Differential (FIS Models) ..... 6-4

Drive Axles ..... 6-19

ACT - Rear Suspension ..... 6-25

Rear Suspension/Rear Drive  
Assembly Schematics ..... 6-29

Rear Gear Case (FIS Models) ..... 6-30

Hub..... 6-30

Hydraulic Brake Caliper..... 6-32

Hydraulic Brake Assembly Schematics..... 6-34

# Drive System

■ **NOTE:** Some photographs and illustrations used in this section are used for clarity purposes only and are not designed to depict actual conditions.

## General Information

All gear cases are tagged beneath a cover bolt. This tag is marked with a production date code, sequence code, and a ratio code.

- A. A “6” on the lower-right corner indicates a 3.6:1 gear set ratio (10:36 teeth).
- B. A “1” on the lower-right corner indicates a 3.1:1 gear set ratio (11:34 teeth).

The die-cast aluminum housings have been assembled with thread-rolling screws (trilobular). When assembling with these screws, start the screws carefully into the housing; then use the following torque values.

Size	New Housing	Reassembled Housing
M6 (Torx T-30 Recess)	1.1-1.3 kg-m (8-9.5 ft-lb)	0.9-1.2 kg-m (6.5-9 ft-lb)
M8 (Torx T-40 Recess)	3.5-4.3 kg-m (25-31 ft-lb)	2.9-3.5 kg-m (21-25 ft-lb)
M10 (Torx T-50 Recess)	5.1-6.3 kg-m (37-45.5 ft-lb)	4.3-5.3 kg-m (31-38 ft-lb)

### SPECIFICATIONS

Specific specifications regarding the the gear cases (capacities, lubricant type, etc.) can be found in Section 1 of this manual.

Ring Gear Backlash	0.28-0.38 mm (0.011-0.015 in.)
Ring Gear End Play	0.1-0.2 mm (0.004-0.008 in.)

## SPECIAL TOOLS

A number of special tools must be available to the technician when servicing the gear case.

Description	p/n
Boot Clamp Pliers	0444-120
Pinion Gear/Shaft Removal Tool	0444-127
Slide Hammer w/CV Joint Attachment	0444-123
CV Joint Attachment (Only)	0444-119
Internal Hex Socket (48 mm)	0444-104

■ **NOTE:** Special tools are available from the Arctic Cat Service Parts Department.

## TROUBLESHOOTING

If a noise is heard from the gear case area, it can be difficult to locate and/or diagnose. If the noise is related to wheel speed, but not to engine RPM, the problem is probably in the final drive or engine/transmission bevel gear set. When a problem is localized, a number of inspections must be made to pinpoint that problem. The most obvious of the inspections include CV boots, wheel and hub nut tightness, wheel bearing damage, gear case lubricant contamination, low lubricant level, seal leakage, CV joints, or selector arm.

■ **NOTE:** Small metallic particles will collect on the magnetic drain plug as a normal part of break-in and will also give a metallic cast to drained lubricant. Contamination would include large particles or water which gives a “milky” look to the lubricant.

■ **NOTE:** Lubricant on a new pinion housing assembly could be grease. If the front of the gear case is leaking at the rear drive boot, wipe excess lubricant from the bottom of the pinion housing; then operate the ATV for a period of time. Inspect the pinion housing area for any signs of leakage. If lubricant is again on the bottom of the pinion housing, the seal must be replaced.

Additional troubleshooting could include the following.

- Binding/abrupt motion: CV boot torn (grease loss, foreign object damage, broken cage); gear lubricant loss or not filled (bearing seizure, broken gear teeth, seal leakage, bladder or hose leakage, missing filler/drain plug).
- Noise from drive system: wheel or gear case bearing damage, improper gear backlash, improper assembly, low or no gear case lubricant.
- Lockup: gear case lubricant loss or not filled, water contamination causing bearing seizure.

# Front Drive Actuator (400 FIS/500/650 H1/650 V-Twin)

■ **NOTE:** The actuator is not a serviceable component. If it is defective, it must be replaced.

■ **NOTE:** The actuator will operate only when the ignition switch is in the ON position.

The front drive actuator is located on the left side of the front drive input housing. With the engine stopped and the ignition switch in the ON position, a momentary “whirring” sound can be heard each time the front drive selector switch is shifted. If no sound is heard, see Section 5. If the actuator runs constantly or makes squealing or grinding sounds, the actuator must be replaced.

## REMOVING

1. Remove the left-front inner fender panel; then disconnect the connector on the actuator harness.
2. Using a T-30 torx wrench, remove the mounting cap screw from the driveshaft side of the actuator.



AG926

3. Remove the mounting cap screw from below the actuator on the suspension side.

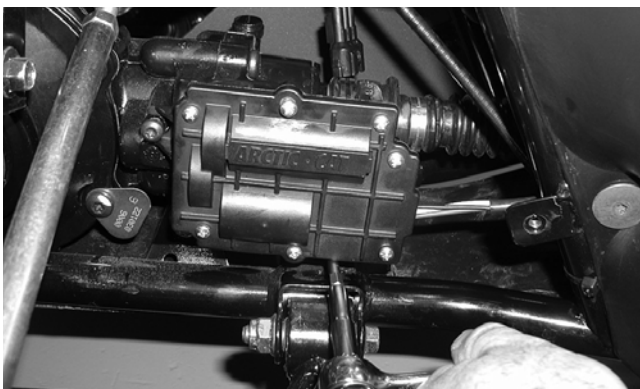

AG927

4. Loosen but do not remove the mounting cap screw at the front of the actuator; then slide the actuator to the rear enough to clear the slotted mounting tab and the selector shaft.

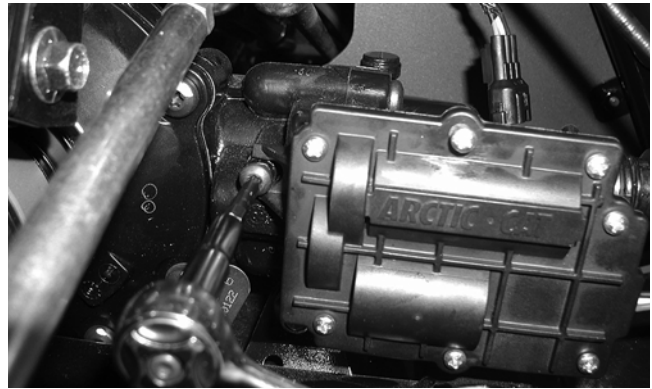

AG928

## INSTALLING

1. Lubricate the O-ring on the actuator; then ensure that all mounting surfaces are clean and free of debris.
2. Align the actuator with the selector shaft and slide it forward onto the shaft taking care to engage the cap screw in the slot of the front mounting tab.

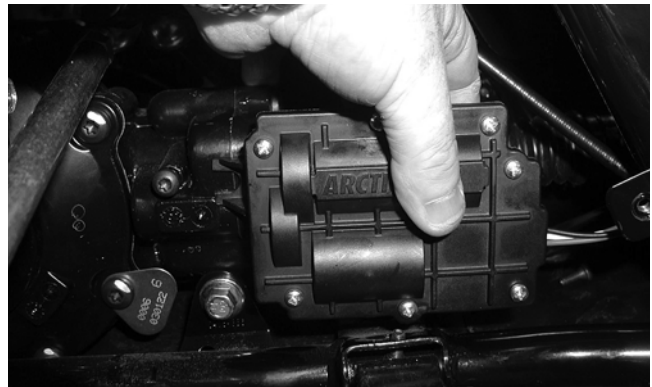

AG925

3. While holding the actuator firmly forward, tighten the front cap screw to hold the actuator in place; then install but do not tighten the two remaining cap screws.

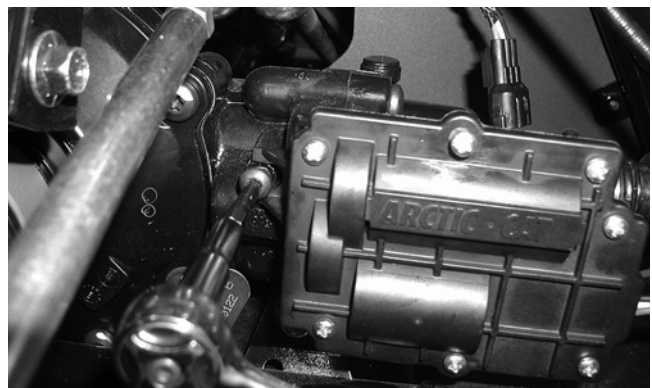

AG928

- Loosen the front cap screw; then tighten the cap screw on the driveshaft side.

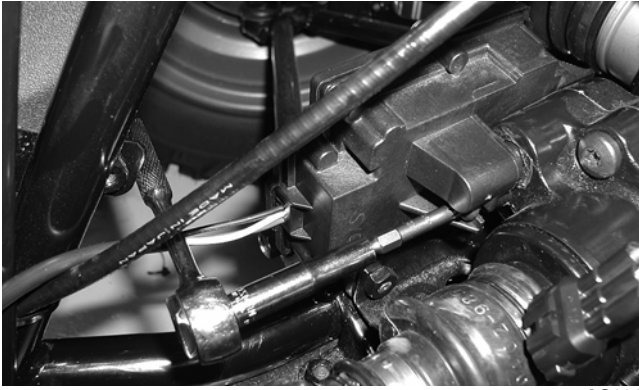

AG926

■ **NOTE:** It is important to tighten this cap screw while the others are loose to ensure proper seating of the actuator.

- Tighten the remaining cap screws; then connect the electrical plug to the main harness.
- Turn the ignition switch to the ON position and check the operation by shifting the selector switch several times.
- Secure the wiring harness to the frame with a nylon cable tie; then install the inner fender panel.

## Front Differential (FIS Models)

■ **NOTE:** To remove the rear gear case on 400 FIS/500 models, see Rear Gear Case (400 FIS/500 Models) in this section.

### REMOVING DIFFERENTIAL

- Secure the ATV on a support stand to elevate the wheels.

#### **WARNING**

**Make sure the ATV is solidly supported on the support stand to avoid injury.**

- Remove the drain plug and drain the gear lubricant into a drain pan; then reinstall the plug.

Front Differential

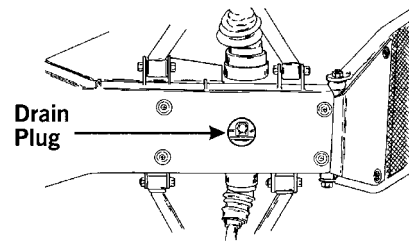

View from Beneath

ATV0082A

- Remove the front wheels.
- Pump up the hand brake; then engage the brake lever lock.
- Remove the cotter pin securing the hex nut; then remove the hex nut and washer.

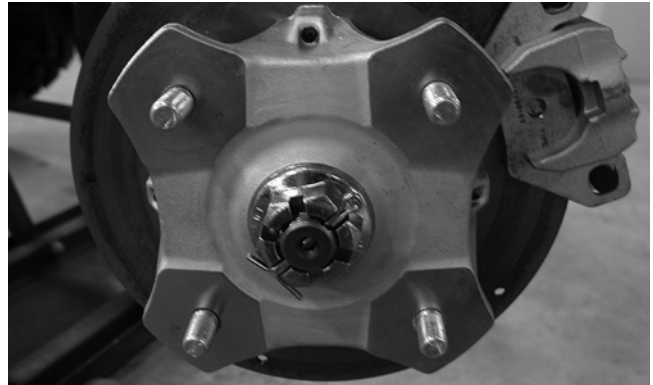

KX041

- Release the brake lever lock.

■ **NOTE:** It is not necessary to remove the brake hoses from the calipers for this procedure.

- Remove the two brake calipers. Account for the four cap screws and four 0.76 mm (0.030 in.) spacer washers.



AF894D

- Remove the tie rod cotter pins and discard the pins.



AF895D

9. Remove the tie rod lock nuts.



AF896D

10. Remove the upper ball joint cap screws taking care not to strip the threads on the ball joint shaft; then using a rubber mallet, tap the end of the axle and free it from the knuckle assembly.

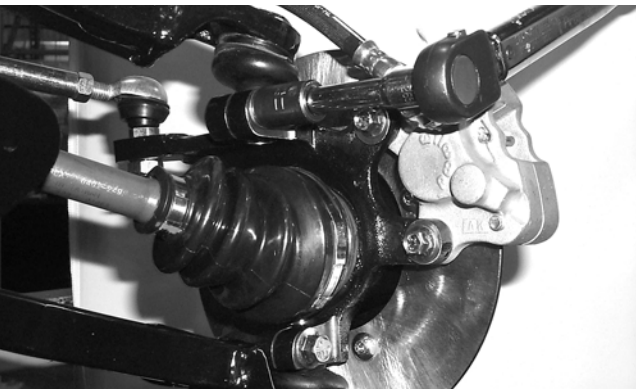

AF628D

11. Pull the steering knuckle away from the axle taking care not to damage the seals with the axle end.



KX151

12. Support the axle to not allow it to drop or hang.

**⚠ CAUTION**  
**The axle must be supported. If the axle is allowed to drop or hang, damage to the inner CV joint may occur.**

13. Remove the lower shock bolts. Account for the lock nuts; then move the shocks aside and secure them with a strap.

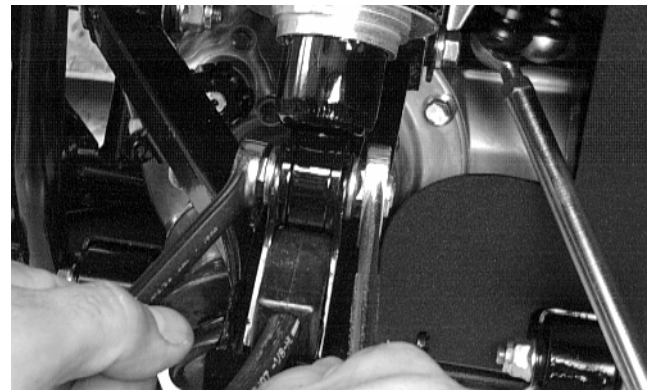

AF897D

14. Remove the upper A-arm lock nuts and cap screws; then remove the A-arms.

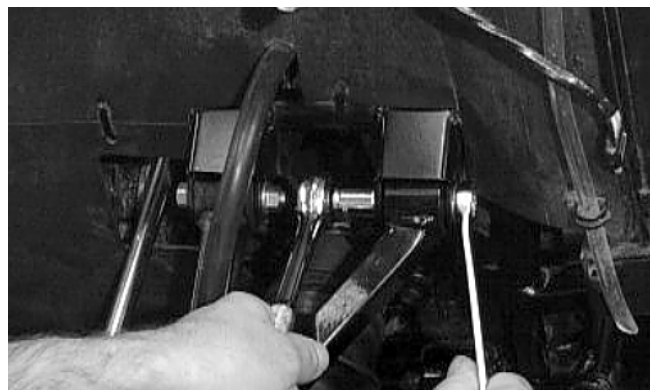

AF610D

15. Using a slide hammer, remove the front axles.



AF899D

16. Remove the inner fender panels.

■ **NOTE:** On the 650 V-Twin, it will be necessary to remove the forward V-belt cooling duct boot and move it to the side.



AF902D

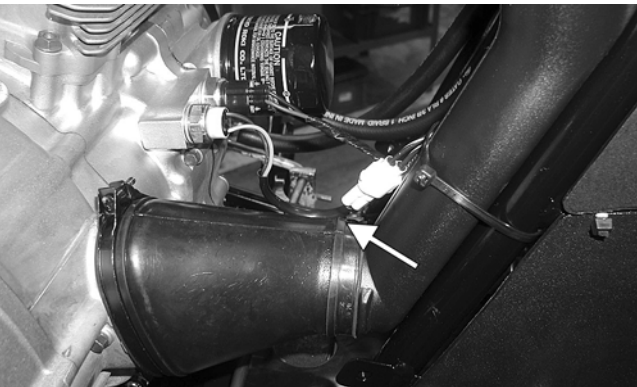

CD517A

17. Using a T-30 torx wrench, remove the three screws securing the front drive actuator to the gear case; then remove the actuator.

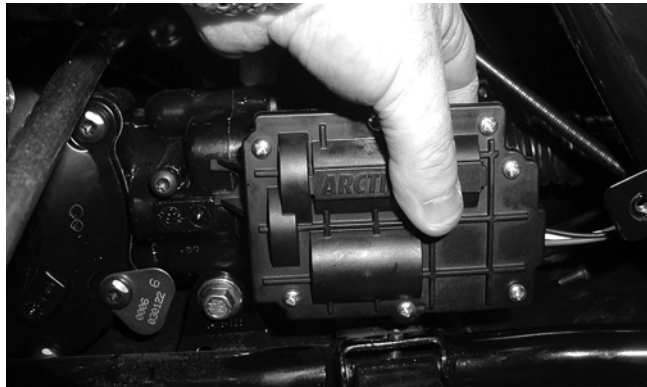

AG925

18. Remove the lower differential mounting cap screw. Account for a lock nut and washers.

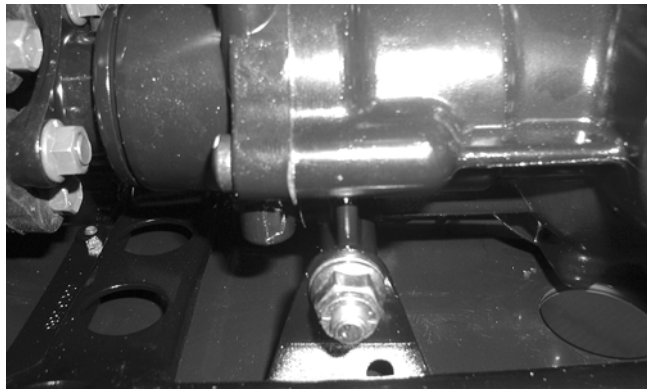

CD026

19. Remove the upper differential mounting cap screws.



CD016

20. Free the differential assembly from the frame mountings; then shift the differential assembly forward enough to disengage the front driveshaft from the output yoke.



KX161

21. Place the differential on its right side; then remove it from the frame.



KX159

**Disassembling Input Shaft**

■NOTE: This procedure can be performed on a rear FIS gear case; however, some components may vary from model to model. The technician should use discretion and sound judgment.

1. Using a T-40 torx wrench, remove the cap screws securing the pinion housing.



CD102

2. Using a rubber mallet, remove the housing. Account for a gasket. Remove the fork, collar, and spring. Note the location of all the components for assembling purposes.

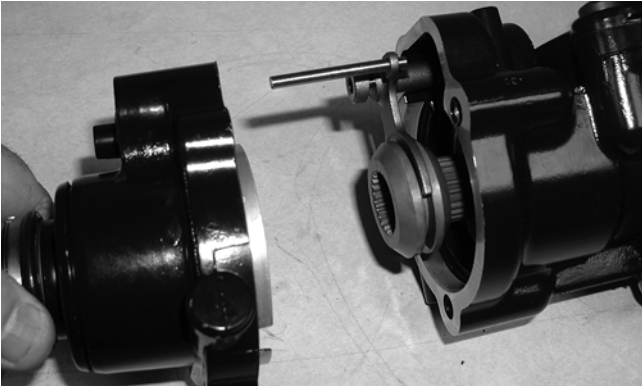

CD103

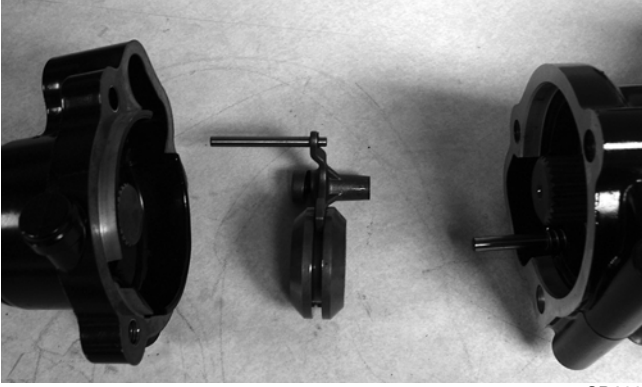

CD106

3. Using a side-cutter (or suitable substitute), remove the boot clamps; then remove the boots and splined drive from the input shaft.

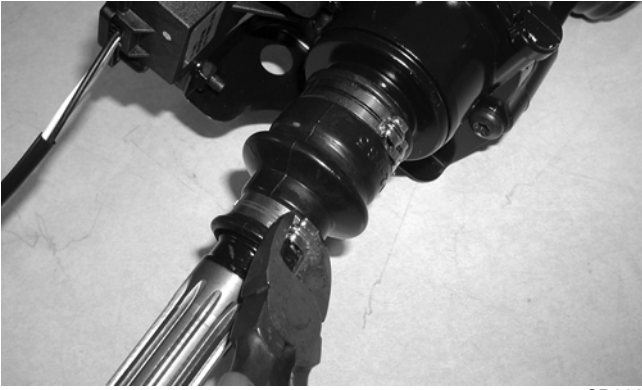

CD114

4. Remove the input shaft from the pinion housing.



CD107

5. Using a seal removal tool, remove the input shaft seal. Account for a spacer.

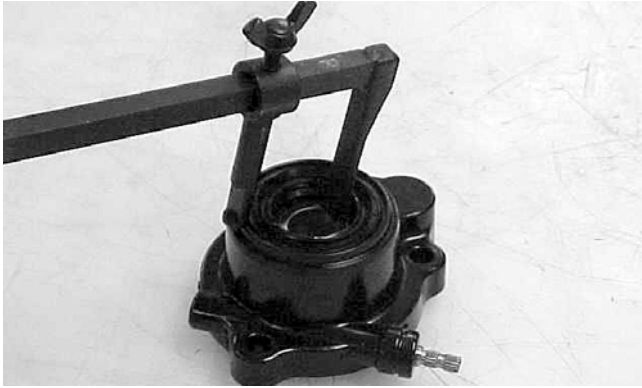

AF982

6. Remove the snap ring securing the input shaft bearing; then place the pinion housing in a press and remove the bearing.



AF983

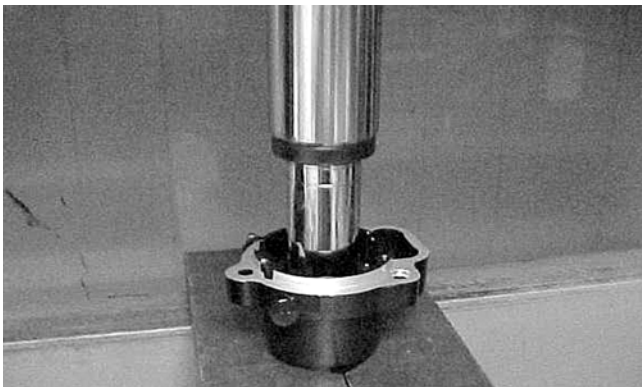

AF984



KX219

### Assembling Input Shaft

1. Place the pinion housing in a press and install the input shaft bearing. Secure the bearing with the existing snap ring making sure the sharp edge of the snap ring faces to the outside.

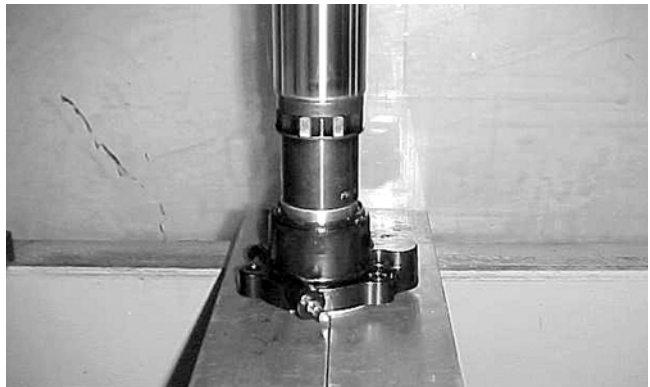

AF993



AF994

2. Install the input shaft seal making sure it is flush with the edge of the housing.

3. Lubricate the input shaft splines with High-Performance Grease (p/n 0436-501).

**NOTE:** Any time drive splines are separated, clean all splines with parts-cleaning solvent and dry with compressed air; then lubricate with recommended grease.





KX221



KX222

4. On the 400 FIS/500/650 H1, install the input shaft into the housing; then install the front boot and secure with Boot Clamp (p/n 0423-393) and the rear boot with Boot Clamp (p/n 0423-411).



CD112



CD099

5. On the 400 FIS/500/650 H1, place the pinion housing with new gasket onto the gear case housing; then secure with the existing cap screws. Tighten to specifications.

■ **NOTE:** If a new gear case housing is being installed, tighten the cap screws to 3.5-4.3 kg-m (25-31 ft-lb).

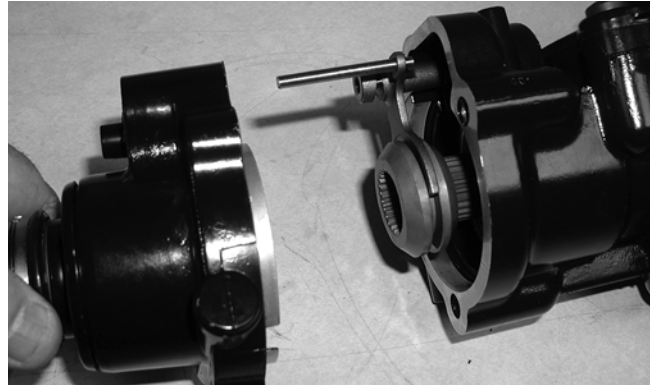

CD103

6. On the 650 V-Twin, install the input shaft into the pinion housing; then secure in the bearing with a circlip.



KX210

7. On the 650 V-Twin, place the pinion housing with new gasket onto the gear case housing; then secure with existing cap screws. Tighten to specifications.

■ **NOTE:** If a new gear case housing is being installed, tighten the cap screws to 3.5-4.3 kg-m (25-31 ft-lb).



KX209

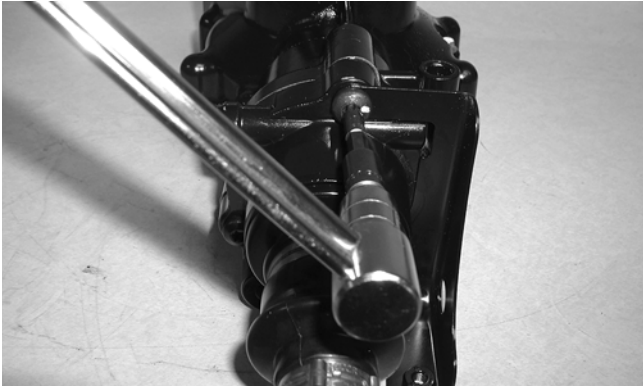

CD110

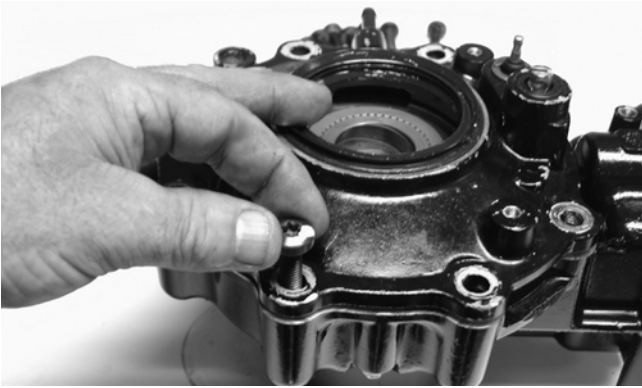

KX173



KX158

**Disassembling Pinion Gear**

■ **NOTE:** This procedure can be performed on a rear gear case.

1. Using a T-40 torx wrench, remove the cap screws securing the pinion housing. Account for the coupler, fork, and spring.



KX209

2. Using a T-40 torx wrench, remove the cap screws securing the gear case cover. Account for and make note of the ID tag location for assembling purposes.

3. Using a plastic mallet, tap lightly to remove the differential cover. Account for an O-ring.



KX174

■ **NOTE:** If the cover is difficult to remove, pry on the cover in more than one recessed location.

4. Remove the splined coupler, shifter fork, pin, and spring of the differential lock assembly and set aside. Note position of parts for assembling purposes.



KX175

5. Make match marks on the left bearing housing and differential housing; then remove the plate and account for a shim. Mark the shim as left-side.

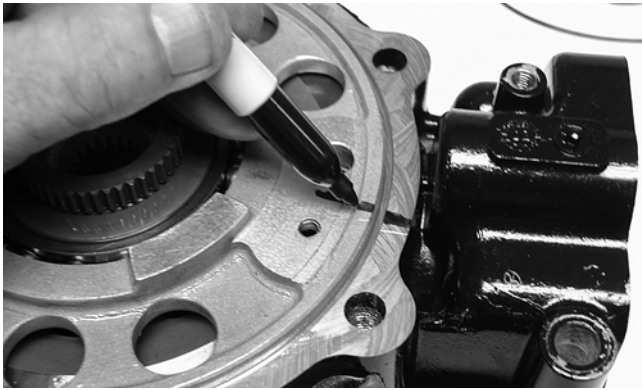

KX176



KX181

7. Using the 48 mm Internal Hex Socket (p/n 0444-104), remove the lock collar securing the pinion gear assembly.

■ **NOTE:** On a front differential, the lock collar has right-hand threads. On a rear gear case, the lock collar has left-hand threads.



KX177

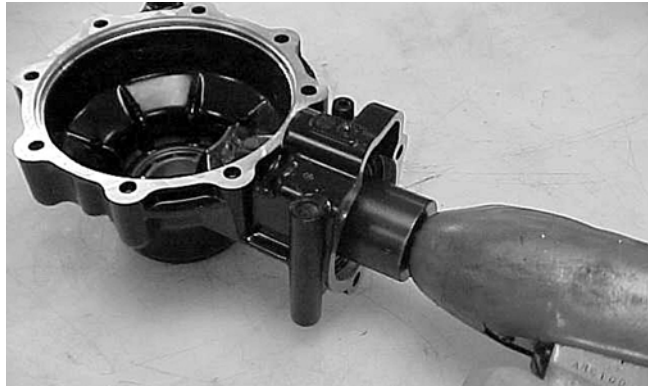

CC875



KX178

6. Place the differential with the open side down; then lift the housing off the spider assembly. Account for shim(s) and mark as right-side.

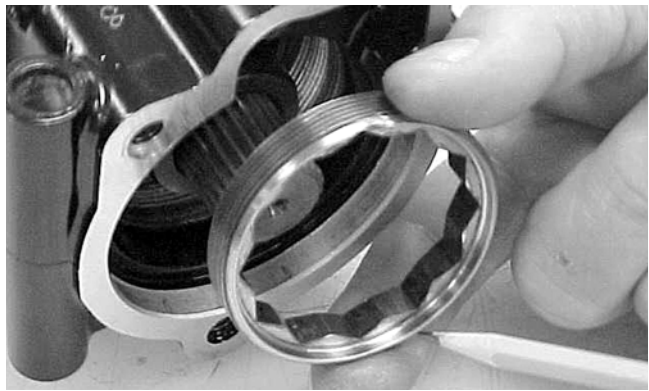

CC876

8. Using the Pinion Gear/Shaft Removal Tool (p/n 0444-127) and a hammer, remove the pinion gear from the gear case housing.



KX179

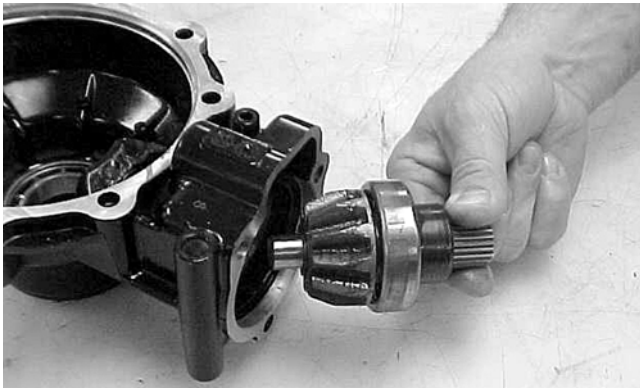

CC878

9. Secure the pinion gear in a bearing puller; then remove the pinion bearing using a press. Account for a collar, a bearing, and a shim.

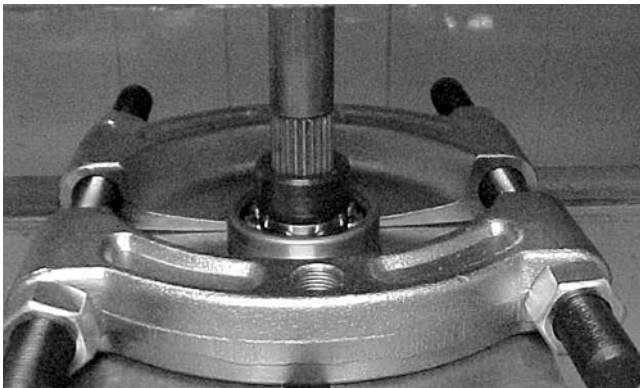

CC879



CC880

■ **NOTE:** If gears are being replaced, use the existing shims. The numbers are scribed onto the gears: the ring gear has the number on the opposite side of the gears, and the pinion gear has the number on the end of the pinion gear shaft by the splines. If no number is present, it should be considered as being in the O category.

■ **NOTE:** If the gear case housing is being replaced, proceed to the following Shimming Procedure/Shim Selection sub-section.

**Shimming Procedure/Shim Selection**

1. Press bearings into bores by outer ring to hard contact with seat.

2. Note the following shim selections (shims are nominally 1.5 mm/0.060 in. thick):

A. Pinion Gear Sub-Assembly - add the value (A) on the gear case housing with 1.5 mm (0.060 in.); then subtract the value on the 10-tooth pinion gear. This will give you the proper shim thickness.

B. Install the lock collar and tighten to specifications; then on final assembling, stake the lock collar edge approximately 1.5 mm (0.060 in.) into the lower oil channel.

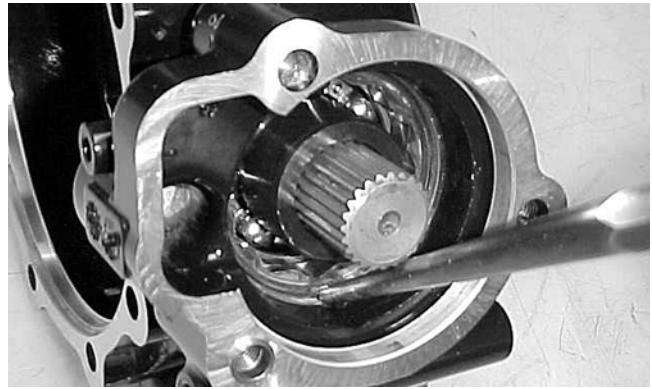

CC891

■ **NOTE:** Do not stake the lock collar until proper backlash has been verified.

C. Cover Side - add the value (B) on the gear case housing to the value (C) on the gear case cover; then add 1.5 mm (0.060 in.). This will give you the proper shim thickness.

D. Gear Case Side - install a 1.3-1.4 mm (0.050-0.055 in.) shim and tighten the bolts to 3.5-4.3 kg-m (25-31 ft-lb). Verify backlash to be within a range of 0.28-0.38 mm (0.011-0.015 in.) and end-play to be within a range of 0.10-0.20 mm (0.004-0.008 in.). If not within specification range, reselect shim until backlash specification range can be verified.

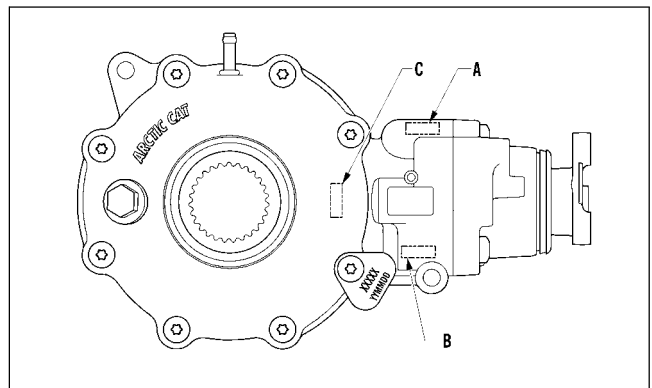

738-268A

3. Prior to final assembling, apply molybdenum disulfide grease to all oil seal lips.

4. Prior to final assembling, prelubricate journal on pinion assembly with SAE 80W-90 hypoid gear lubricant prior to pressing assembly into gear case housing.

### Assembling Pinion Gear

1. Place the shim ( with the chamfer side toward the inside) onto the pinion shaft; then install the bearing onto the pinion shaft. Install the pinion shaft collar.

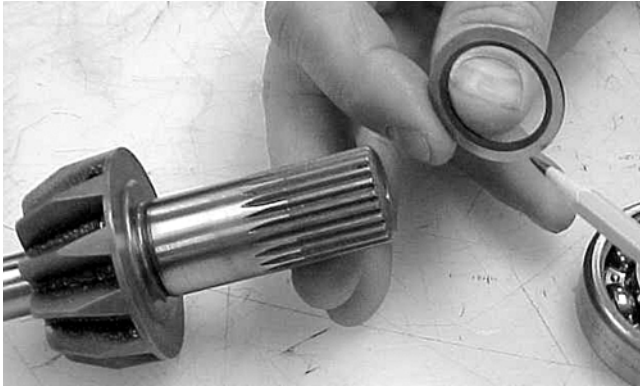

CC881

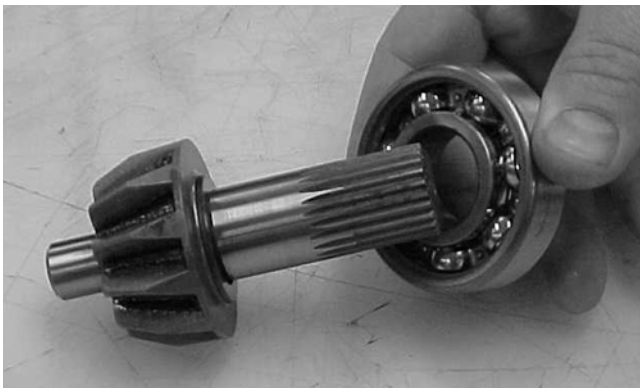

CC882

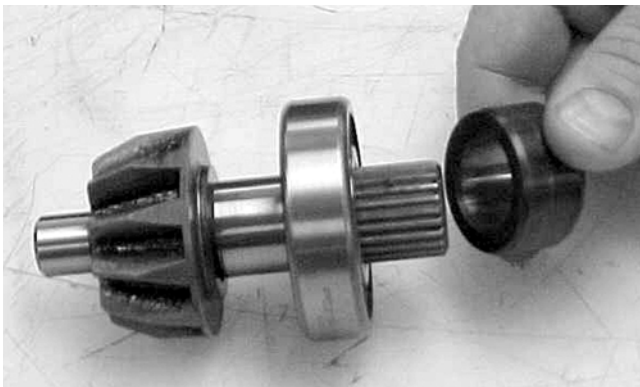

CC883

2. Place the pinion assembly in a bearing puller; then install the bearing using a press.

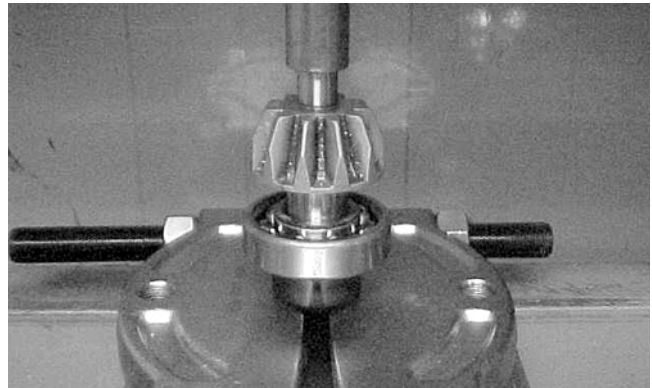

CC884

3. Install the pinion gear assembly into the housing. Using the 48 mm Internal Hex Socket (p/n 0444-104), secure the pinion gear assembly with the existing lock collar. Tighten to specifications.

■ **NOTE:** On a front differential, the lock collar has right-hand threads. On a rear gear case, the lock collar has left-hand threads.

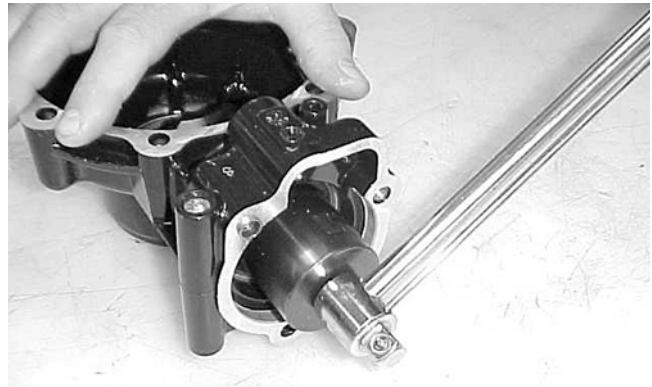

CC890

4. Place a punch on the edge of the lock collar in the oil gallery area; then using a hammer, stake the lock collar to ensure that the collar will remain securely tightened.

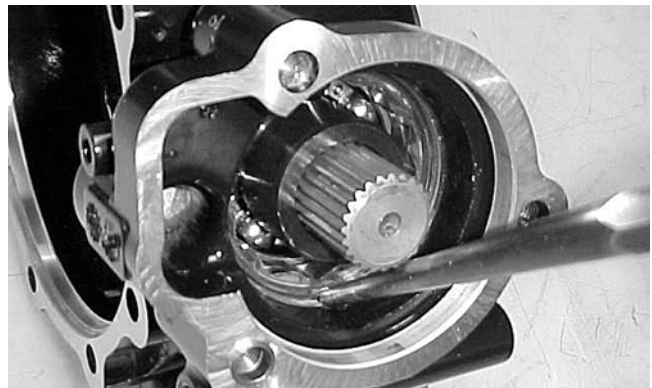

CC891

5. Install the shift fork shaft w/spring into the gear housing making sure the shaft O-ring is positioned to the inside.

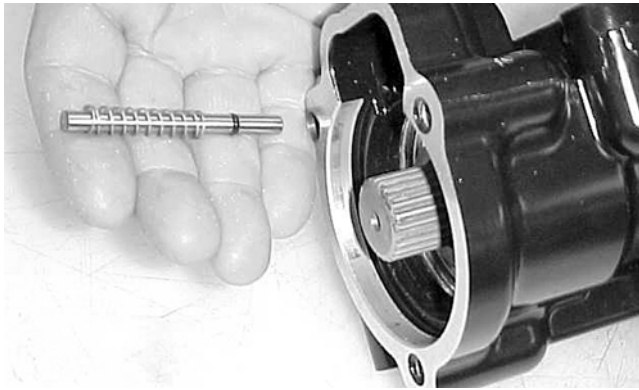

CC892

6. Install the shift fork assembly making sure the fork leg is facing upward. Apply a small amount of oil to the gasket; then install the gasket.

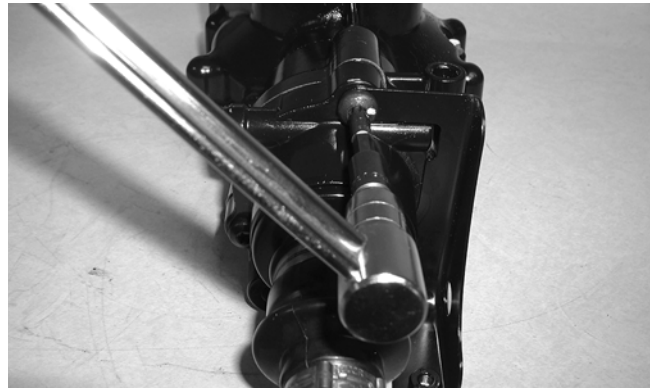

CD110

8. Install the proper shim onto the ring gear spider assembly making sure the chamfer side of the shim is facing toward the ring gear. Install the ring gear in the housing; then install the outside shim with the chamfer side of the shim toward the ring gear.

■ **NOTE:** The spider and ring gear assembly must be replaced as a complete unit.

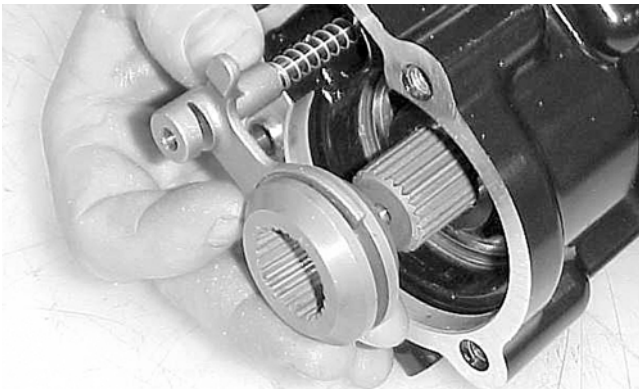

CC893

7. Place the input shaft assembly onto the gear housing; then secure with the existing cap screws. Tighten to specifications.

■ **NOTE:** If a new gear housing is being installed, tighten the cap screws to 3.5-4.3 kg-m (25-31 ft-lb).

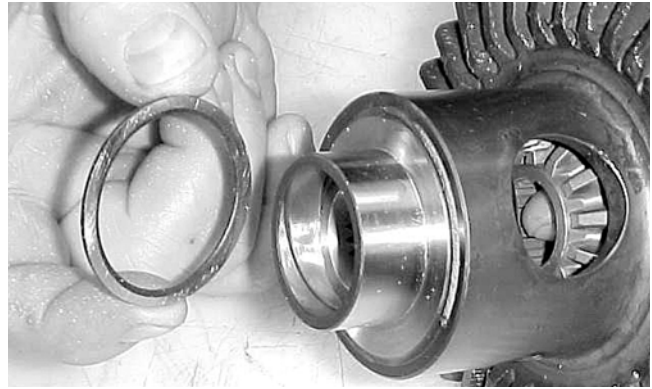

CC896

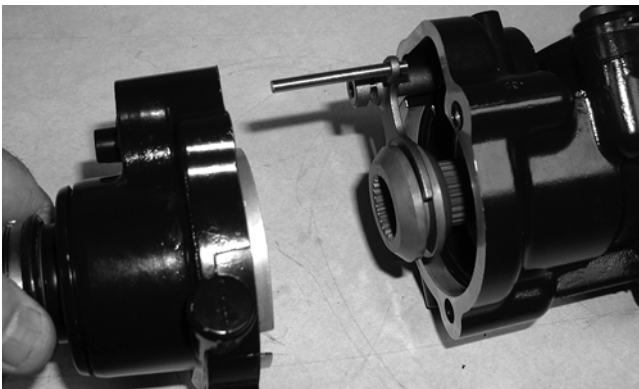

CD103

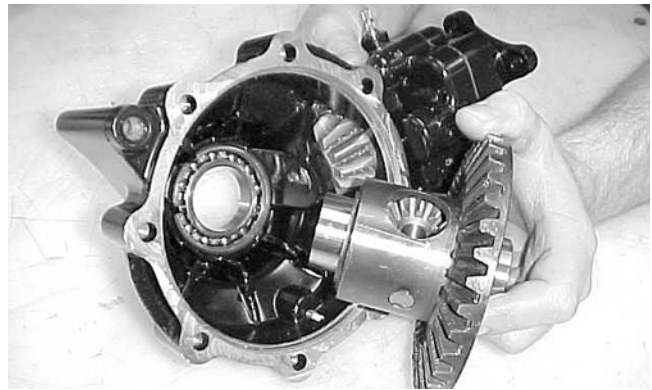

CC897



KX178

9. Install the left bearing housing aligning the match mark to the mark on the differential housing.



KX177

10. Install the differential lock assembly into the bearing housing; then place the O-ring on the gear case housing.



KX175



KX174

11. Making sure the O-ring is properly positioned on the gear case housing, install the housing with existing hardware. Account for the ID tag. Tighten the cap screws to specifications.

■ **NOTE:** Grease can be applied to the O-ring for ease of assembling.

■ **NOTE:** If a new gear case housing is being installed, tighten the cap screws to 3.5-4.3 kg-m (25-31 ft-lb).

**Removing Needle Bearing**

■ **NOTE:** Removing the needle bearing is rarely necessary. Avoid removing the needle bearing unless the bearing is clearly damaged.

■ **NOTE:** This procedure can be performed on a rear gear case.

1. Place a 6.35 mm (1/4 in.) drill bit on the inside surface of the needle bearing (against the bottom side); then drill through the pinion shaft needle bearing housing.

**6**

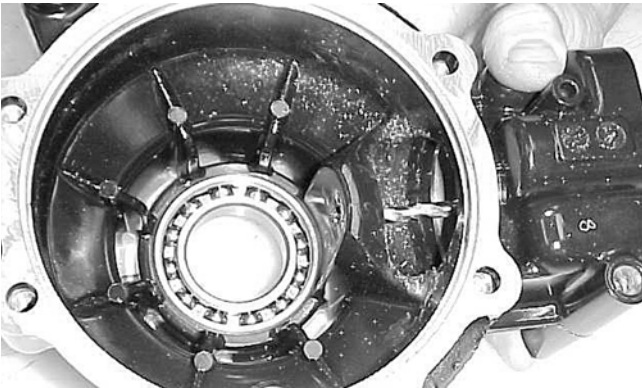

CC885

2. Using a propane torch, heat the area surrounding the needle bearing to soften the Loctite.

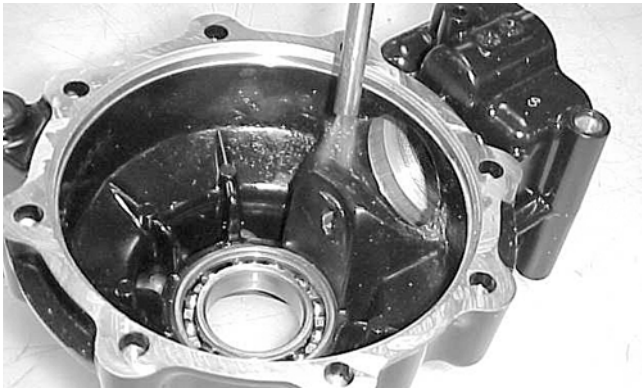

CC886

- Using a flat-nosed punch, drive the bearing out of the housing.

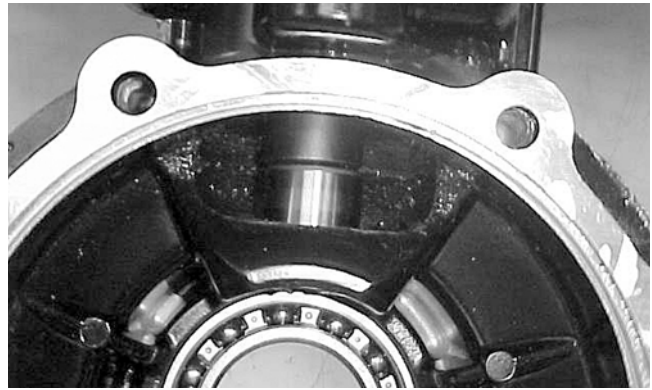

CC889

- Install the pinion shaft and secure with the existing 48 mm lock collar. Tighten to specifications.



CC887

### Installing Needle Bearing

- Apply red Loctite #271 to the outside of a new bearing; then place the new bearing into the housing.

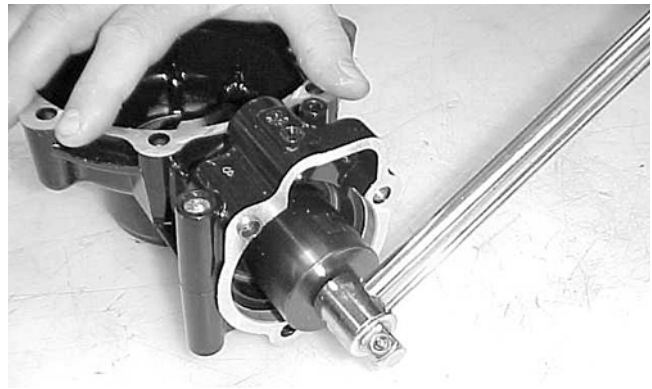

CC890

- Place a punch on the edge of the lock collar in the oil gallery area; then using a hammer, stake the lock collar to ensure that the collar will remain securely tightened.

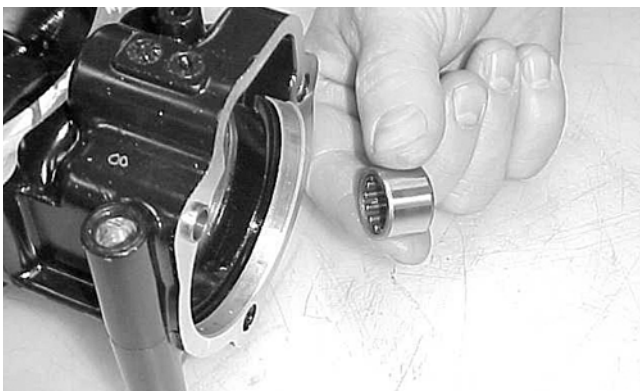

CC888

- Using a suitable driver, install the needle bearing into the gear case housing making sure the bearing is seated.

■ **NOTE:** Do not push the bearing too far into the housing.

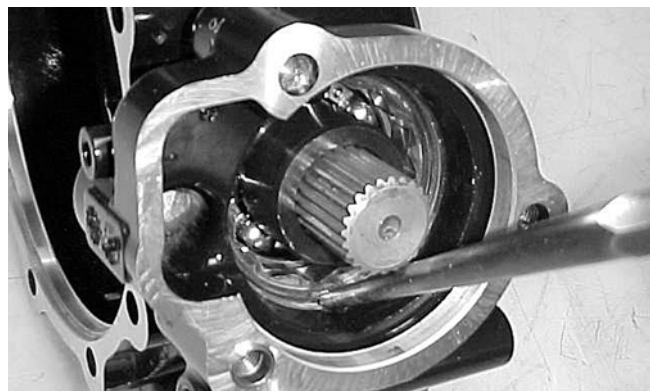

CC891

- Install the pinion housing.

### Removing/Installing Axle Seal

■ **NOTE:** This procedure can be performed on a rear gear case.

- Remove the seal using a seal removal tool.



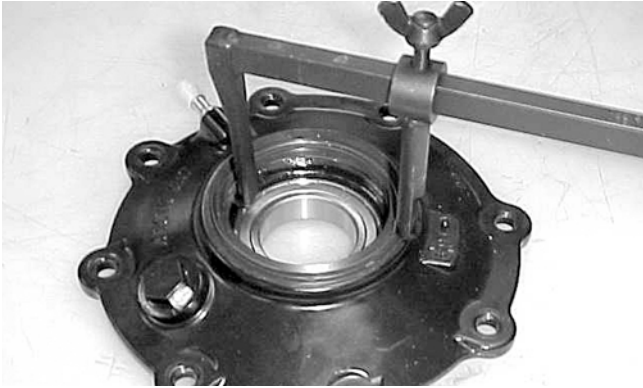

CC899

2. Using a press, remove the bearing.

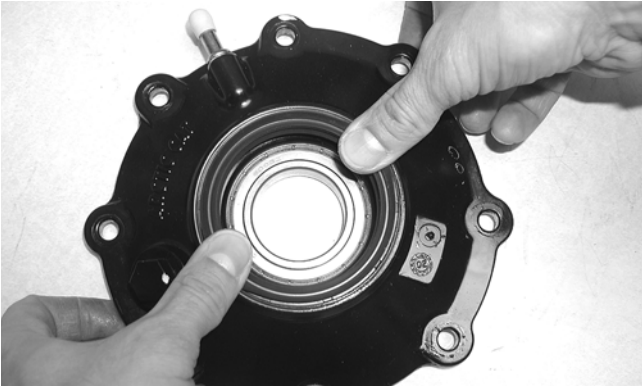

CD018

5. Repeat steps 1-4 for the opposite side.

**INSTALLING DIFFERENTIAL**

1. Align the splined input yoke with the front output splines; then place the differential into position on the frame and install the cap screws, washers, and flex-lock nuts. Tighten to specifications. Make sure the rubber boot is properly seated on the input yoke.



CC900

3. Using a press, install the new bearing into the housing.



KX161

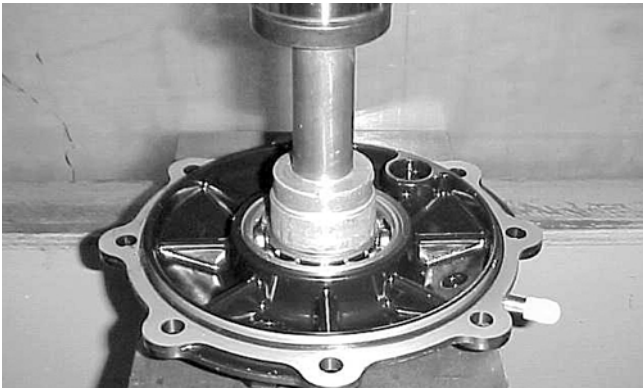

CC901

■ **NOTE:** Prior to installing the seal, apply grease to the seal outside diameter.

4. Install the seal into the housing pressing evenly on the outside edge until the seal is seated.



AF905D

7. Secure the lower shock eyelets with cap screws and lock nuts. Tighten to specifications.

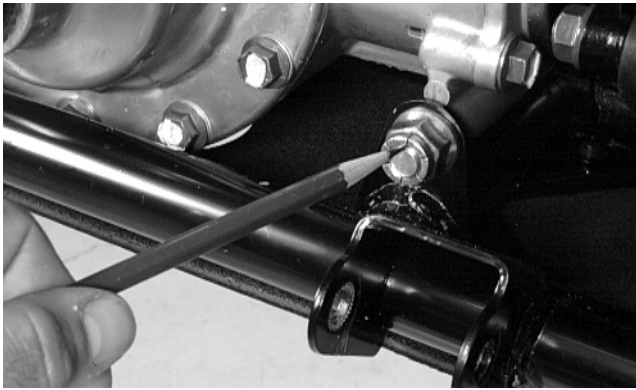

AF904D

2. Pour 275 ml (9.3 fl oz) of SAE 80W-90 hypoid lubricant into the differential and install the filler plug. Tighten to specifications.
3. Install the front drive actuator with the three torx-head cap screws; then connect the wire connector to the main wiring harness.

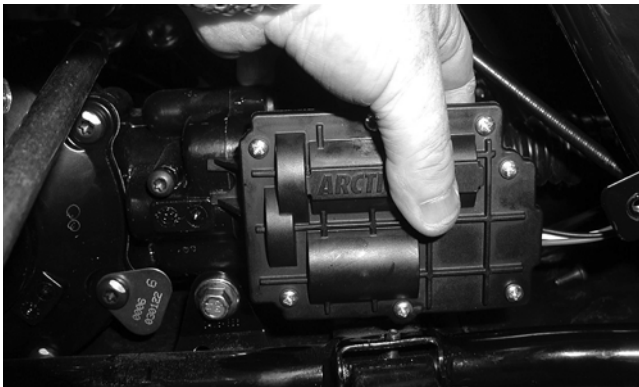

AG925

4. Install the inner fender panels.
5. Install the front axles (see Drive Axles in this section).
6. Secure the upper A-arms with cap screws and lock nuts. Tighten to specifications.

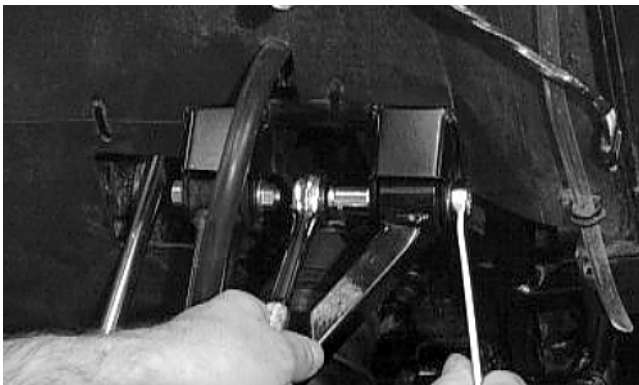

AF610D

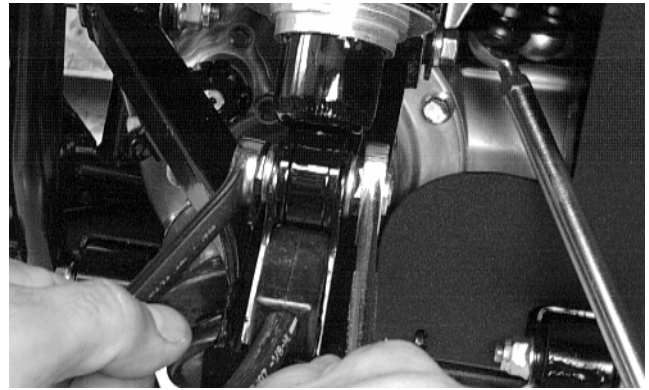

AF897D

8. Secure the tie rods with the lock nuts. Tighten to specifications; then install and spread the cotter pins.



AF896D



AF895D

9. Making sure that each caliper has the 0.76 mm (0.030 in.) spacer washers between the caliper and the knuckle, install the brake calipers. Secure with the cap screws tightened to specifications.

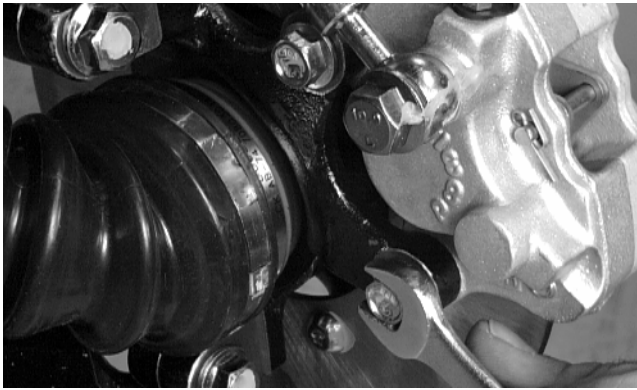

AF894D

10. Install the wheels and tighten to specifications.
11. Remove the ATV from the support stand.

## Drive Axles

### REMOVING REAR DRIVE AXLE (Fully Independent Suspension)

1. Secure the ATV on a support stand to elevate the wheels.

**⚠ WARNING**

**Make sure the ATV is solidly supported on the support stand to avoid injury.**

2. Pump up the hand brake; then engage the brake lever lock.
3. Remove the wheel.
4. Remove the cotter pin securing the hex nut; then remove the hex nut. Release the brake lever lock.

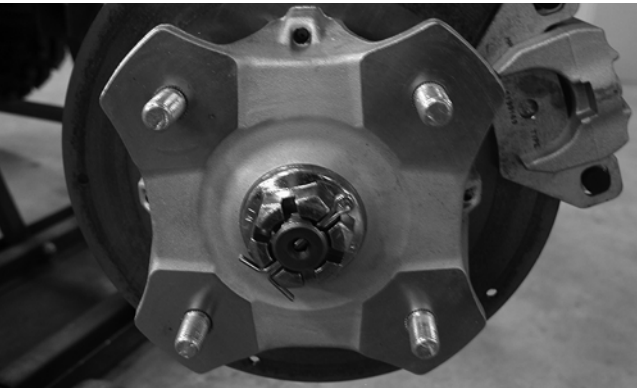

KX041

5. Remove the two brake calipers (right side only).

■ **NOTE:** Do not allow the brake calipers to hang from their cable/hose.

**⚠ CAUTION**

**The calipers should be supported. If the calipers are allowed to hang from the cable/hose, damage may occur.**

6. Slide the hub out of the knuckle and set aside.
7. Remove the cap screw and lock nut securing the knuckle to the upper A-arm. Discard the lock nut.

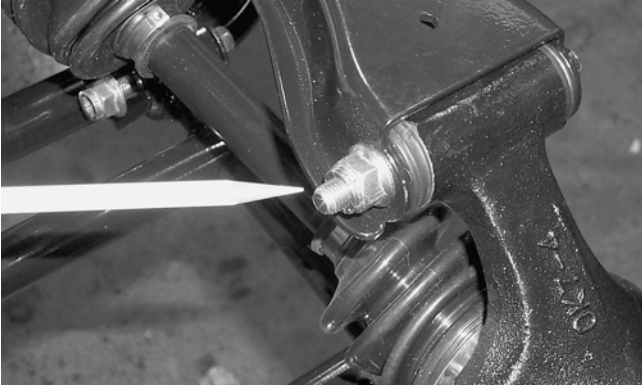

AF936

■ **NOTE:** Never reuse a lock nut. Once a lock nut has been removed, it must be replaced with a new lock nut.

8. While holding the drive axle stationary, pull the top of the knuckle out and down until it is free of the drive axle.
9. Place a drain pan under the ATV to contain any oil leakage; then using a slide hammer, remove the drive axle.

# 6



AF935

### REMOVING FRONT DRIVE AXLE (4x4 Models)

■ **NOTE:** For removing a front drive axle on a 4x4 model, see Front Differential (FIS Models) in this section.

## CLEANING AND INSPECTING

■ **NOTE:** Always clean and inspect the drive axle components to determine if any service or replacement is necessary.

1. Using a clean towel, wipe away any oil or grease from the axle components.



CD019

2. Inspect boots for any tears, cracks, or deterioration.

■ **NOTE:** If a boot is damaged in any way, it must be replaced with a boot kit.

## DISASSEMBLING AXLES

1. Using a side-cutters (or suitable substitute), remove the large clamp from the boot.



CD020

2. Wipe away excess grease to access the retaining ring. Using an awl or circlip pliers, remove the circlip.

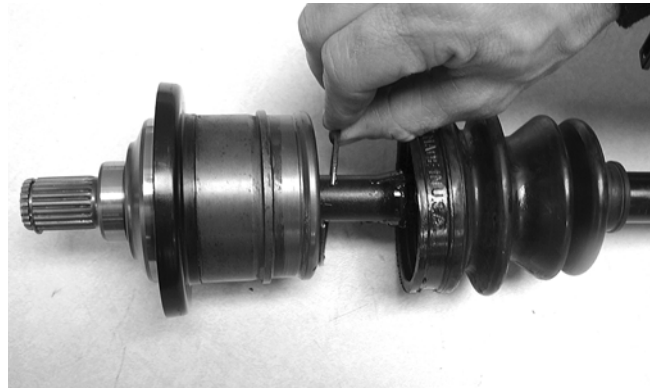

CD021

3. Using a snap ring pliers, remove the circlip securing the bearing ring to the shaft. Note the direction of the bearing for assembling purposes.

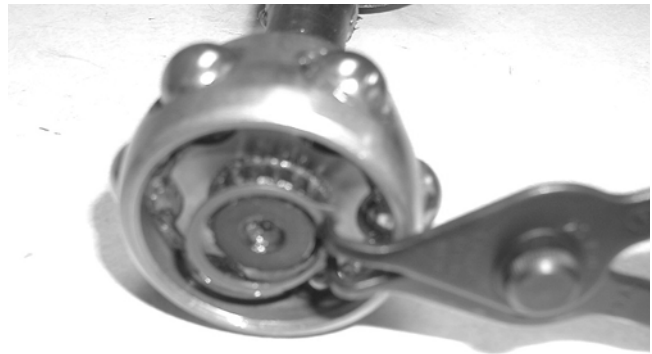

CD023

4. Note the difference inside each bearing ring end for assembling purposes; then remove the bearing ring.

■ **NOTE:** The recess of the bearing must face toward the housing.



CD022

5. Inspect the splines of the shaft, the bearing ring, and the housing for damage.

■ **NOTE:** If any damage is apparent to the splines, the bearing ring, and/or the housing, the drive axle must be replaced as an assembly.

6. Using a side-cutters (or suitable substitute), remove the small clamp from the shaft.



CD752

■ **NOTE:** At this point if the outside boot is damaged, continue with step 7.

- Using a side-cutters (or suitable substitute), remove both outside boot clamps from the shaft. Note the position of the different-sized clamps for assembling purposes.

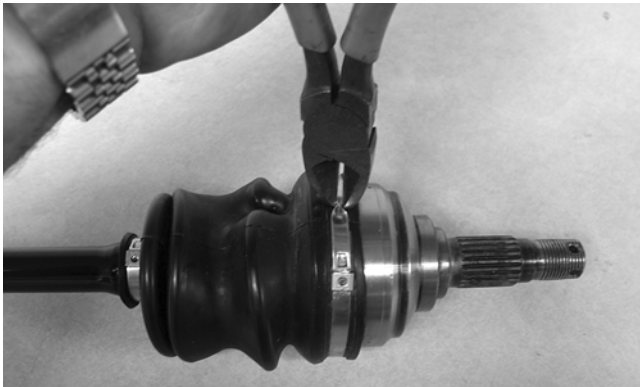

CD751

- Apply 40 grams (1/3 of contents) of grease from the Grease Pack (p/n 0441-173) into the knuckles and the new outside boot.

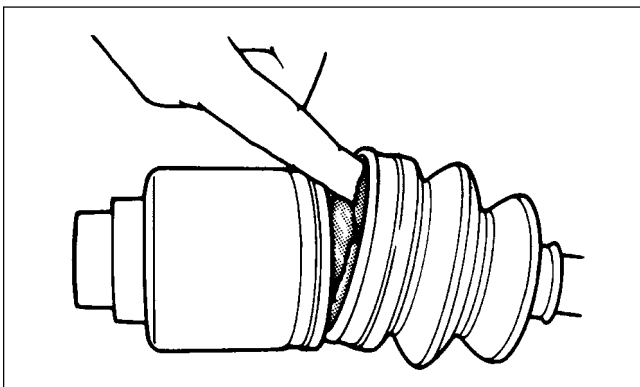

ATV-1052

■ **NOTE:** Grease Pack (p/n 0441-173) contains 120 grams of grease. The inside joint (double-offset) requires approximately 70-90 grams of grease and the outside (bell-type) requires approximately 35-55 grams. When replacing boots, use 2/3 of the pack for inside boots and 1/3 of the pack for outside boots.

**CAUTION**

Do no over-fill the joint as boot damage may occur resulting in joint failure.

- Slide the new outside boot onto the shaft with the new clamps positioned as shown. Note the different-sized clamps from removal.

■ **NOTE:** The boot is positioned correctly when the small end of the boot seats down into the recessed groove.



CD754

- Using Boot Clamp Pliers (p/n 0444-120), secure both outside boot clamps.

**CAUTION**

It is important that the clamps are positioned correctly or they may loosen when in motion.



CD024

**ASSEMBLING AXLES**

- Install the inner boot with the small clamp making sure the ends of the clamp are positioned correctly.

■ **NOTE:** The boot is positioned correctly when the small end of the boot seats down into the recessed groove.



CD754

- Using the boot clamp pliers, secure the small clamp of the inner boot.

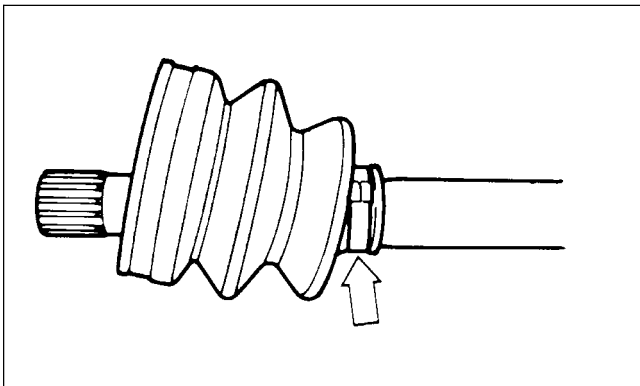

ATV-1048

- Apply 80 grams (2/3 of contents) of grease from the pack into the bearing housing.
- Install the bearing onto the shaft making sure the recess of the bearing is facing the housing.



CD022

**CAUTION**

The bearing ring must go onto the shaft with the side without splines facing toward the small clamp of the inner boot or severe damage will result.

- Secure the bearing ring with the circlip making sure the sharp side of the circlip faces away from the boot.

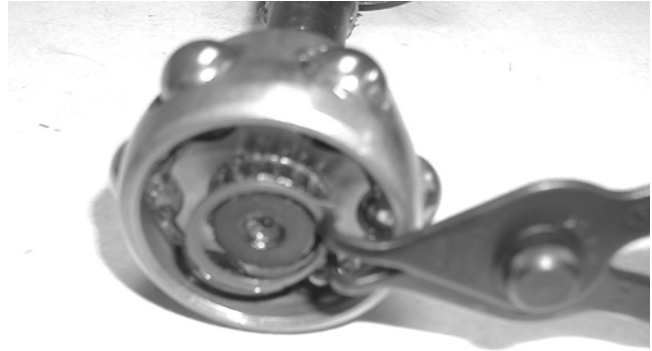

CD023

- Making sure the marks made during disassembling align, slide the housing over the bearing ring; then completely seat the bearing ring into the housing and install the circlip.

■ **NOTE:** Pull the bearing ring out of the housing until it contacts the circlip; then slide the ring in half way. This will purge air from the housing and ensure the bearing is packed properly.

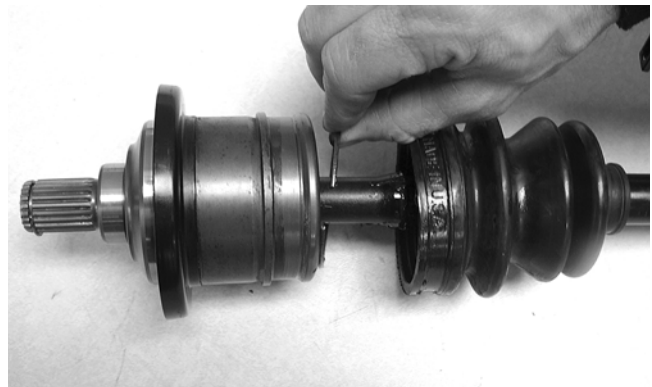

CD021

- Slide the boot over the housing; then using the boot clamp pliers, secure the boot with the clamp.



CD024

- Inspect the axle components for correct positioning of the four clamps. Also, inspect the boots for being correctly positioned on the shaft.

## INSTALLING REAR DRIVE AXLE (Fully Independent Suspension)

1. Slide the drive axle into place in the gear case.

■ **NOTE:** To assure proper seating of the axle, give it a light pull; the axle should remain “clipped” in place.

2. Swing the knuckle up and onto the drive axle; then place the knuckle into place in the upper A-arm. Secure the knuckle to the A-arm with a cap screw and a new lock nut. Tighten to specifications.
3. Place the hub into position on the axle followed by a hex nut. Tighten the hex nut finger-tight at this time.
4. If the brake calipers were removed, position them on the knuckle and secure with existing cap screws. Tighten the auxiliary brake caliper cap screws to specifications. Tighten the hydraulic brake caliper cap screws to specifications.
5. Pump up the hand brake lever; then engage the brake lever lock.
6. Tighten the hub hex nut (from step 3) to specifications; then install and spread a new cotter pin making sure each side of the pin is flush to the hub nut.

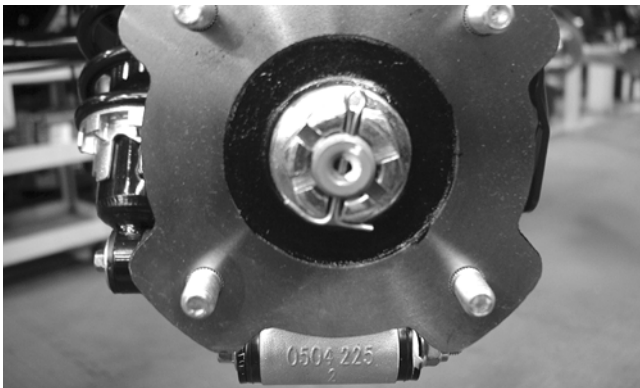

CD027

7. Install the wheel. Tighten to specifications.
8. Remove the ATV from the support stand and release the brake lever lock.

## INSTALLING FRONT DRIVE AXLE (4x4 Models)

1. Position the drive axle in the gear case and steering knuckle; then insert the upper A-arm ball joint into the steering knuckle. Secure with a cap screw tightened to specifications.

2. Place the brake hose into position on the upper A-arm; then secure the lower shock eyelet to the A-arm with a cap screw and a new lock nut. Tighten to specifications.
3. Secure the tie rod to the steering knuckle with a new lock nut. Tighten securely; then install and spread a new cotter pin.
4. Slide the hub w/brake disc into position in the steering knuckle followed by a washer and hex nut. Tighten finger-tight at this time.
5. Install the brake caliper on the steering knuckle. Tighten to specifications; then pump up the hand brake lever and engage the brake lever lock.
6. Tighten the hub hex nut (from step 4) to specifications; then install and spread a new cotter pin making sure each side of the pin is flush to the hub nut.

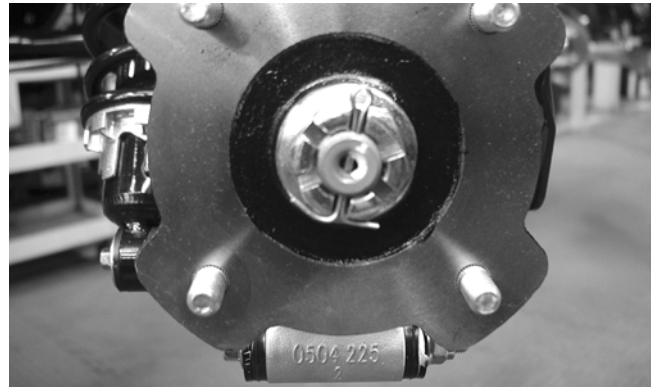

CD027

6

7. Install the wheel and tighten to specifications.
8. Remove the ATV from the support stand and release the brake lever lock.
9. Check the front differential oil level and add oil as necessary.

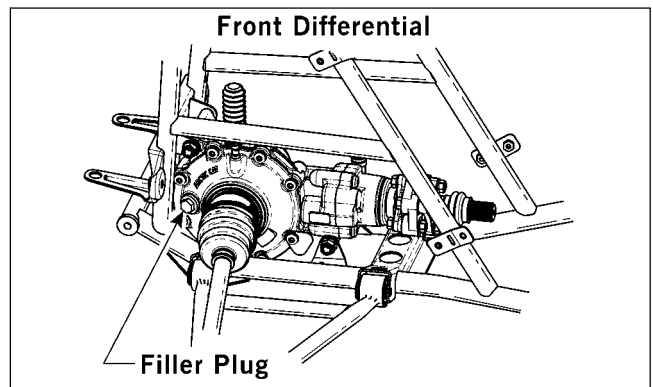

0736-568

# ACT - Rear Suspension

## REMOVING

1. Place the ATV on a support stand (positioned just in front of and behind the footrest on each side) so the wheels are off the floor.

**⚠ WARNING**

**Make sure the ATV is solidly supported on the support stand to avoid injury.**

2. Remove the rear wheels.
3. Remove the cap screws securing the brake calipers to the bearing housing; then remove the calipers and lay aside.

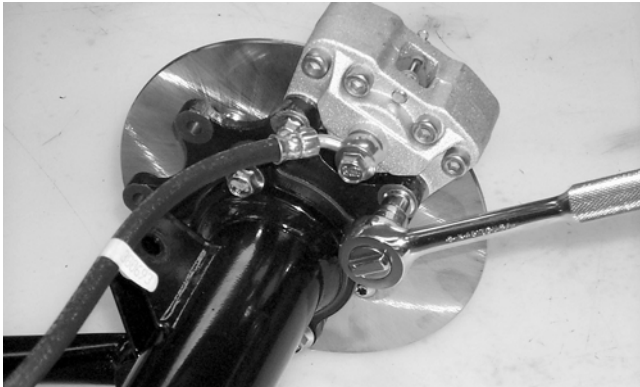

CC783

**⚠ CAUTION**

**Care should be taken not to damage the brake cable/hose when laying the calipers aside. Do not allow the calipers to hang from the brake cable/hose.**

4. Remove the lower shock absorber cap screws and hex nuts; then disengage the shock absorbers from the axle housings.

**⚠ CAUTION**

**Ensure that the rear gear case is properly supported BEFORE removing the shock absorber assemblies.**

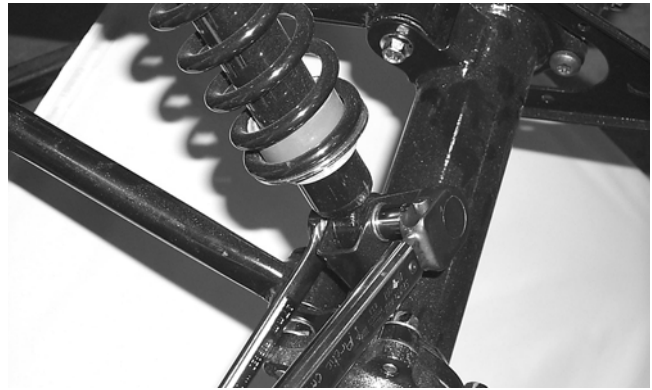

AF772D

5. Remove the four cap screws and nuts securing the rear of the swing arm(s) to the axle housing.

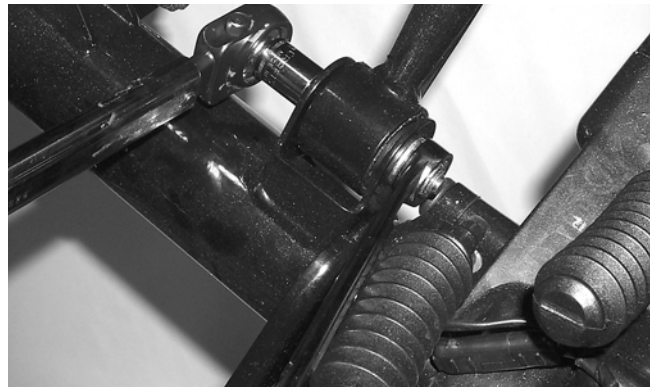

AF697D

6. Maneuver the axle assembly rearward allowing the propeller shaft to disengage and the final drive boot to separate from the drive housing.

## DISASSEMBLING

1. Remove the cap screws securing the gear case panel; then remove the panel from the gear case.

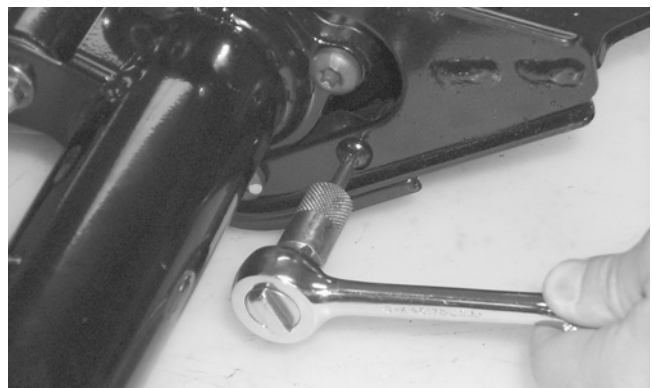

CC762



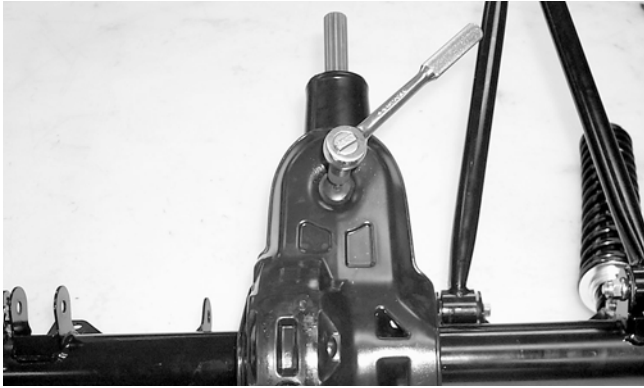

CC763

2. Remove the cap screws securing the axle assembly to the axle housing; then remove the axle assembly from the housing. Account for a gasket.

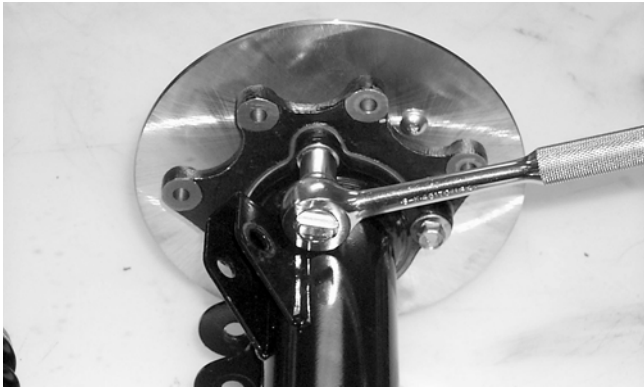

CC764

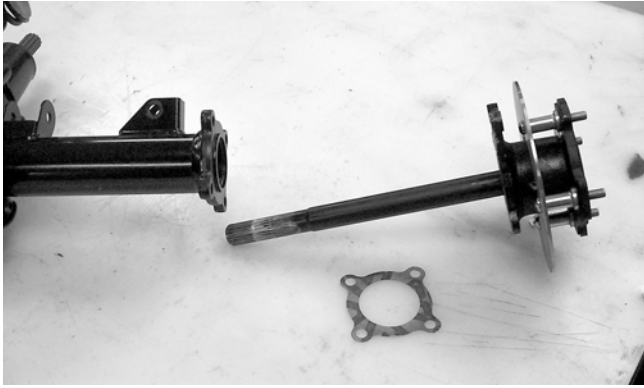

CC765

3. Remove the snap ring securing the bearing housing to the axle shaft; then slide the bearing housing off the shaft.

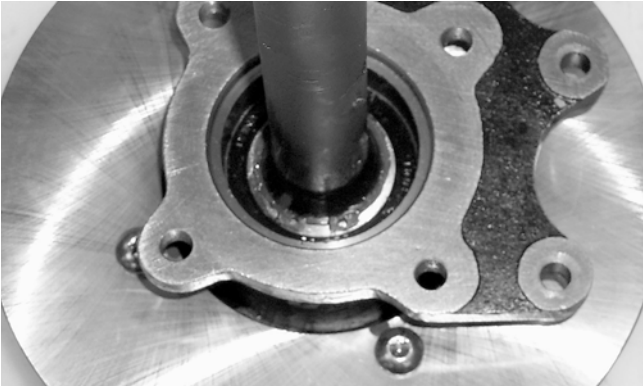

CC768A

4. Remove the four cap screws securing the hitch to the gear case; then remove the hitch.

■ **NOTE:** Note that these cap screws are 37 mm (1.5 in.) in length for installing purposes.

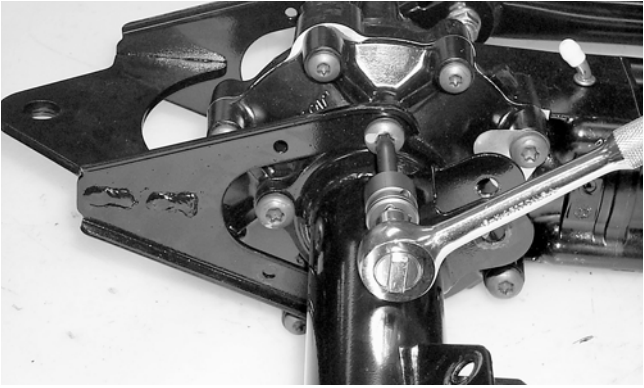

CC769

5. Remove the two cap screws securing each axle housing to the gear case.

■ **NOTE:** Note that these cap screws are 33 mm (1.3 in.) in length for installing purposes.



CC770

6. Remove the axle housing from the gear case. Account for a gasket.

6



CC771

## CLEANING AND INSPECTING

■ **NOTE:** Whenever a part is worn excessively, cracked, or damaged in any way, replacement is necessary.

1. Clean all external components.
2. Inspect the case for leaks or damage.
3. Inspect splines for wear.
4. Inspect the seal for damage.
5. Inspect housing mounting bosses for wear or elongated holes.
6. Inspect the frame welds for cracking or bending.
7. Inspect the rear drive and plug threads for stripping or damage.
8. Inspect the axle bearings. Rotate the bearings by hand, and if any roughness or binding is noted, replace the bearings.

## ASSEMBLING

1. Grease the splines of the ring gear.
2. Make sure the rear gear case/axle housing O-ring is properly positioned; then secure the axle housing to the rear gear case with two 33 mm (1.3 in.) cap screws. Tighten to specifications.

■ **NOTE:** If a new gear case is being installed, tighten the cap screws to 5.1-6.3 kg-m (37-45.5 ft-lb).



CC770

3. Secure the axle housing to the rear gear case with four 37 mm (1.5 in.) cap screws. Tighten to specifications.

■ **NOTE:** If a new gear case is being installed, tighten the cap screws to 5.1-6.3 kg-m (37-45.5 ft-lb).

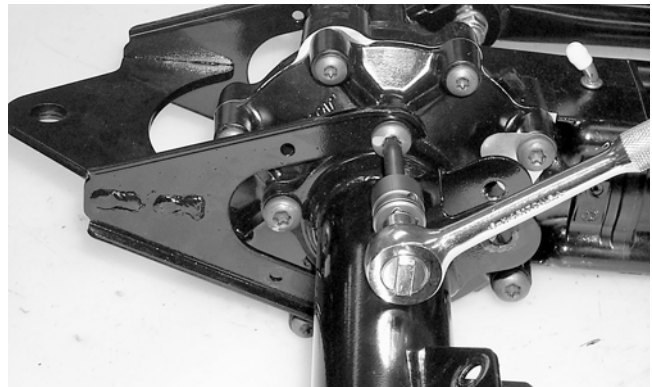

CC769

4. Lightly grease the bearing housing seal; then slide the bearing housing onto the axle shaft. Secure with the snap ring.

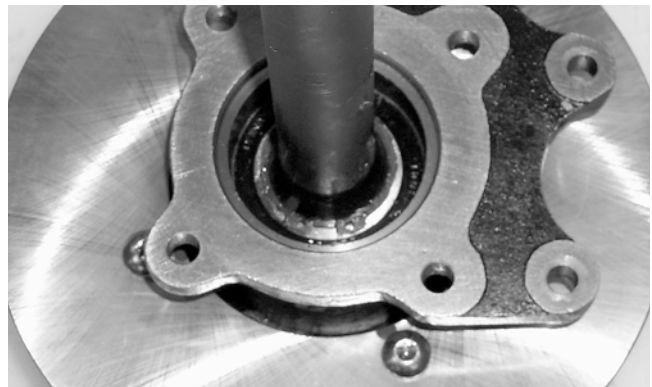

CC768

5. Place the axle gasket on the axle housing. Rotate the axle shaft slightly to ensure proper engagement with the gear case splines.
6. Rotate the bearing housing until the brake caliper mounting holes are on the top side; then secure the axle retainer assembly/axle assembly to the axle housing with four cap screws. Tighten to specifications.

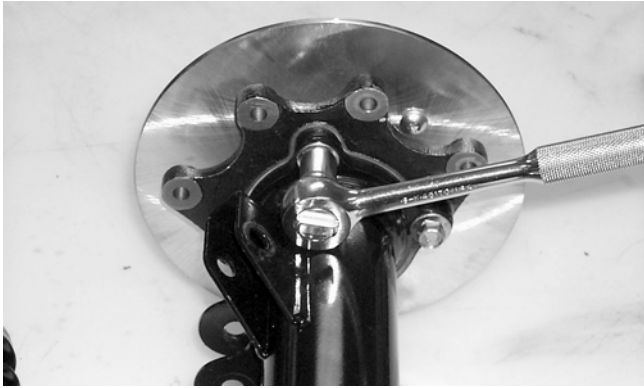

CC764

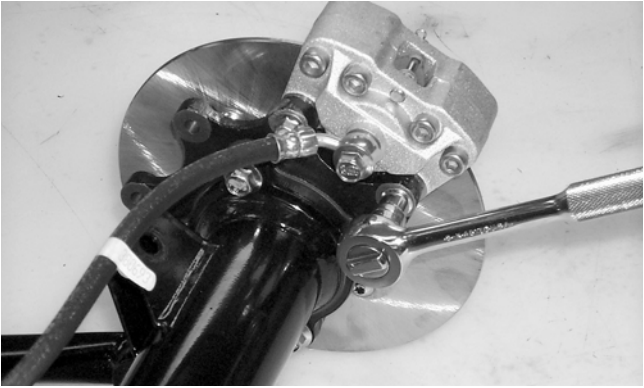

CC783

**INSTALLING**

1. Maneuver the axle assembly forward making sure propeller shaft splines engage properly and the final drive boot is positioned over the drive housing.
2. Place the rear of the swing arm(s) into position on the axle housings and case; then secure with four cap screws and hex nuts. Tighten to specifications.

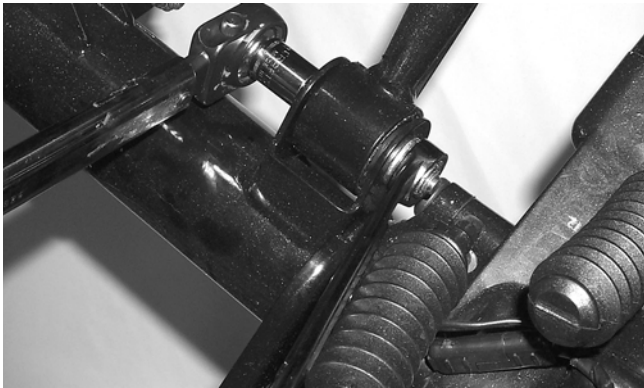

AF697D

3. Place the shock absorber into the frame mounts and secure using the cap screws and hex nuts tightened to specifications.

**CAUTION**  
Do not tighten nuts beyond the 4.8 kg-m (35 ft-lb) specification or the shock eyelet or mount WILL be damaged.

4. Place the brake calipers into position on the axle retainer assembly; then secure with the cap screws. Tighten the auxiliary caliper to specifications and the hydraulic caliper to specifications.

**CAUTION**  
Care should be taken not to damage or kink the brake cable/hose when installing the calipers.

5. Place the gear case panel into position and secure with the three cap screws. Tighten securely.

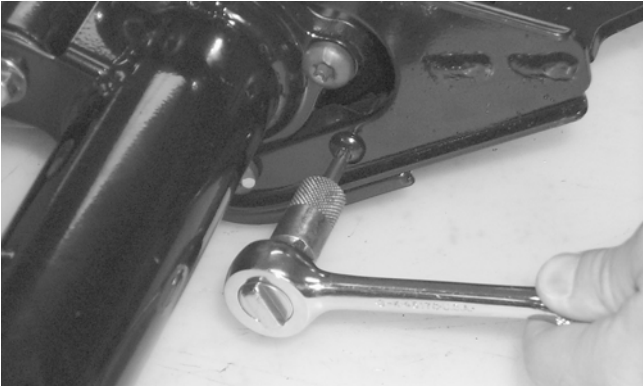

CC762

**6**

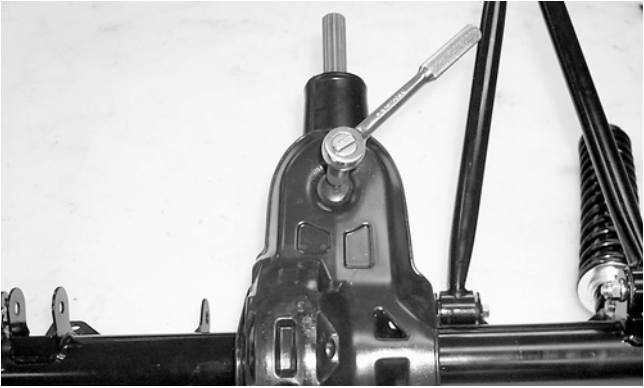

CC763

6. Install the wheels and tighten to specifications.
7. Remove the ATV from the support stand.

**NOTE:** Check all fasteners for tightness and check the brakes for proper operation before test riding.

# Rear Suspension/Rear Drive Assembly Schematics

■ NOTE: Some components may vary from model to model. The technician should use discretion and sound judgment.

**KEY**

- 1. Knuckle
- 2. Knuckle
- 3. Seal
- 4. Seal
- 5. Wheel Bearing
- 6. Clip
- 7. Collar
- 8. Bushing
- 9. Cap Screw
- 10. Lock Nut
- 11. A-Arm
- 12. Bushing
- 13. Collar
- 14. A-Arm
- 15. Cap Screw
- 16. Axle
- 17. Clip
- 18. Boot Repair Kit
- 19. Boot Guard
- 20. Body Screw
- 21. Boot Guard
- 22. Shock Absorber
- 23. Bushing
- 24. Sleeve
- 25. Adjuster Cam
- 26. Retainer
- 27. Spring
- 28. Cap Screw
- 29. Washer
- 30. Cap Screw
- 31. Spanner Wrench

## REAR SUSPENSION/AXLE ASSEMBLY - FULLY INDEPENDENT SUSPENSION

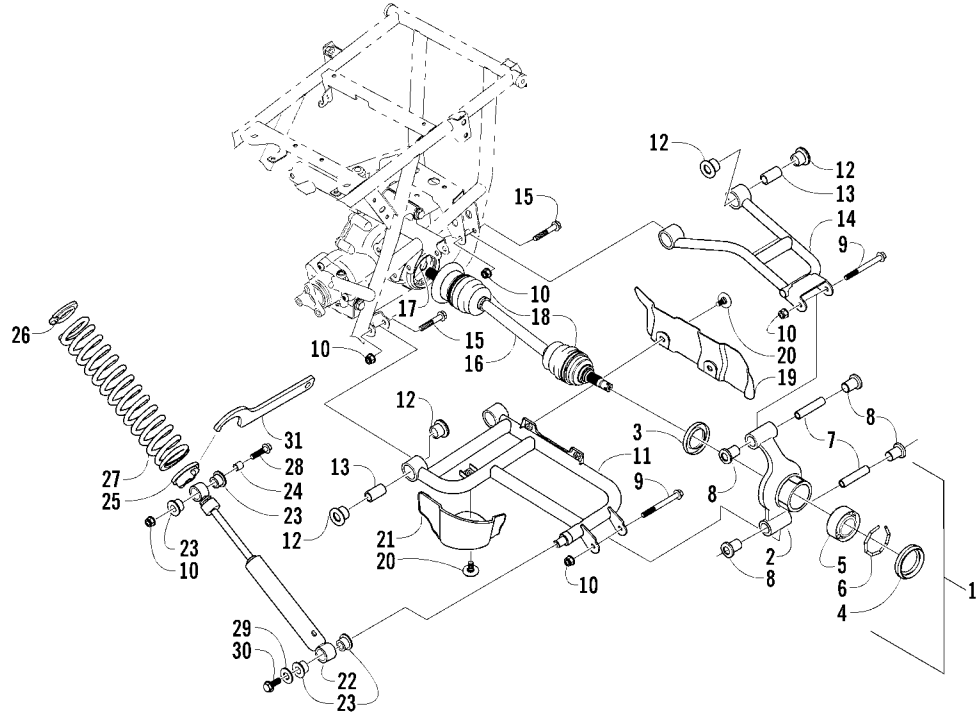

0738-570

**KEY**

- 1. Gear Case Assy
- 2. Housing
- 3. Bearing
- 4. Seal
- 5. Ring Gear
- 6. Shim
- 7. Thrust Button
- 8. Shim
- 9. O-Ring
- 10. Cover
- 11. Filler Plug
- 12. O-Ring
- 13. Fitting
- 14. Self-Tapping Screw
- 15. Magnetic Plug
- 16. O-Ring
- 17. Bearing
- 18. Pinion Gear Assy
- 19. Shim
- 20. Bearing
- 21. Collar
- 22. Dowel Pin
- 23. Lock Collar
- 24. Wave Washer
- 25. Collar
- 26. Gasket
- 27. Pinion Housing
- 28. Retaining Ring
- 29. Bearing
- 30. Retaining Ring
- 31. Seal
- 32. Input Shaft
- 33. Bumper
- 34. Propeller Shaft
- 35. Clamp
- 36. Boot
- 37. Output Flange
- 38. Cap Screw
- 39. Cap Screw
- 40. Washer
- 41. Lock Nut
- 42. Clamp
- 43. Vent Hose
- 44. Vent Fitting
- 45. Clip
- 46. Bladder

## REAR DRIVE GEAR CASE ASSEMBLY - FULLY INDEPENDENT SUSPENSION

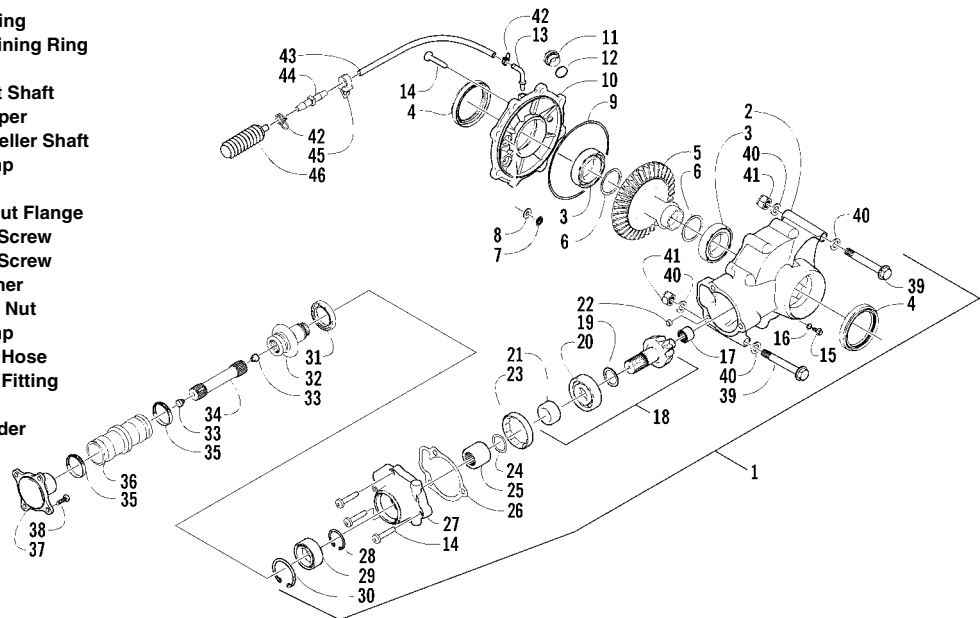

0738-395

## Rear Gear Case (FIS Models)

### REMOVING

1. Remove the left-side rear A-arms (see Rear A-Arms in Section 7).
2. Remove both of the rear drive axles (see Drive Axles in this section).
3. Remove the four cap screws securing the engine output shaft to the rear gear case input flange.

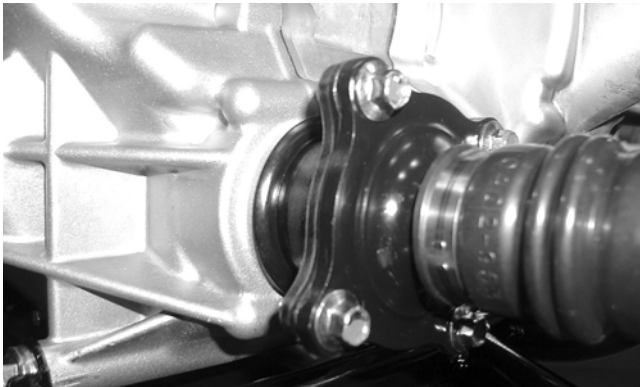

CD028

4. Remove the two cap screws and lock nuts securing the rear gear case to the frame; then remove the gear case through the left side.

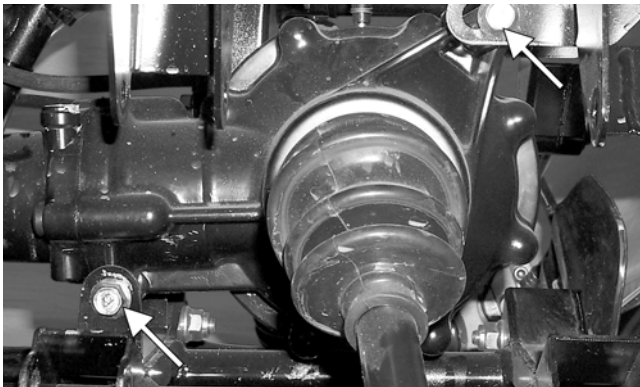

AF960A

### AT THIS POINT

For servicing the input shaft, pinion gear, needle bearing, and axle seal on FIS models, see Front Differential (FIS Models) in this section.

### INSTALLING

1. Slide the gear case into position through the left side of the frame; then secure it to the frame with cap screws and lock nuts. Tighten to specifications.

■ **NOTE:** If a new gear case is being installed, tighten the cap screws to 5.1-6.3 kg-m (37-45.5 ft-lb).

2. Secure the engine output shaft to the rear gear case input flange with three cap screws (coated with red Loctite #271) and lock nuts. Tighten to specifications.
3. Install the rear drive axles (see Drive Axles in this section).
4. Install the left-side rear A-arms (see Rear A-Arms in Section 7).

## Hub

### REMOVING

1. Secure the ATV on a support stand to elevate the wheel; then remove the wheel.

### WARNING

Make sure the ATV is solidly supported on the support stand to avoid injury.

6

2. Remove the cotter pin from the nut.

■ **NOTE:** During assembly, new cotter pins should be installed.

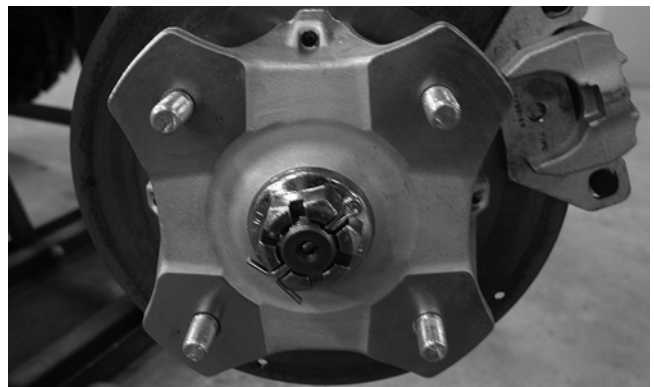

KX041

3. Remove the flange nut securing the hub.
4. Remove the brake caliper.

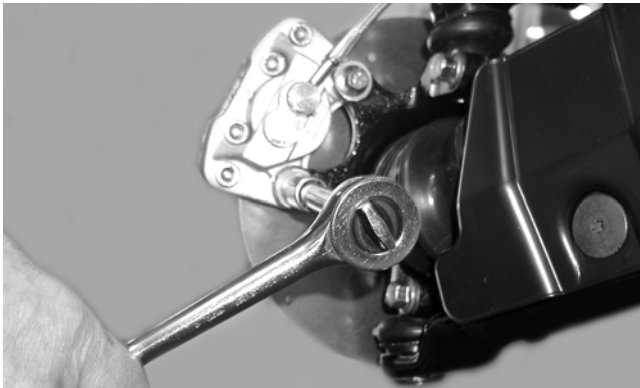

CD007

5. Remove the hub assembly.
6. Remove the four cap screws securing the brake disc.

### CLEANING AND INSPECTING

■ **NOTE:** Whenever a part is worn excessively, cracked, or damaged in any way, replacement is necessary.

1. Clean all hub components.
2. Inspect all threads for stripping or damage.
3. Inspect the brake disc for cracks or warping.
4. Inspect the hub for pits, cracks, loose studs, or spline wear.

### INSTALLING

1. Secure the brake disc to the hub with the four cap screws coated with blue Loctite #243. Tighten to specifications.
2. Apply grease to the splines in the hub.

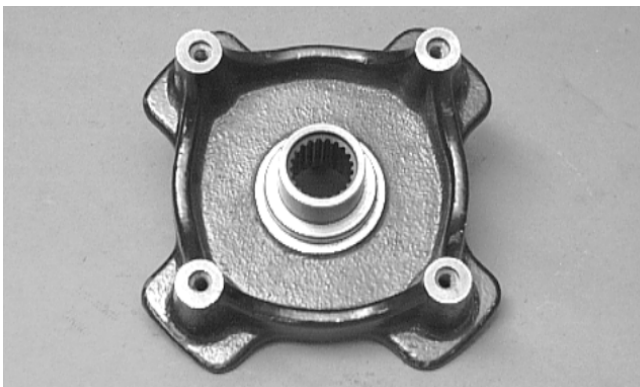

AF736D

3. Install the hub assembly onto the shaft.

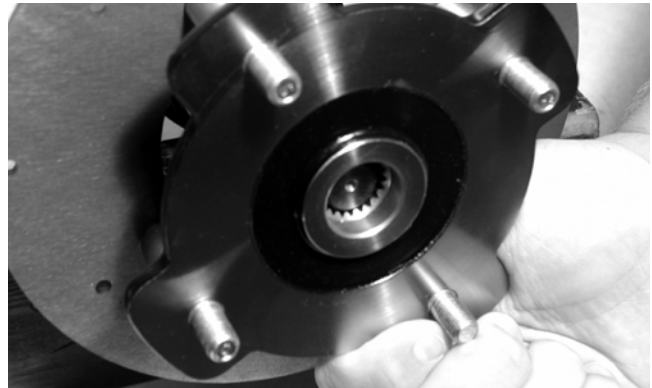

CD009

4. Secure the hub assembly with the nut. Tighten only until snug.
5. Secure the brake caliper to the knuckle with the two cap screws. Tighten the auxiliary caliper to specifications. Tighten the hydraulic caliper to specifications.

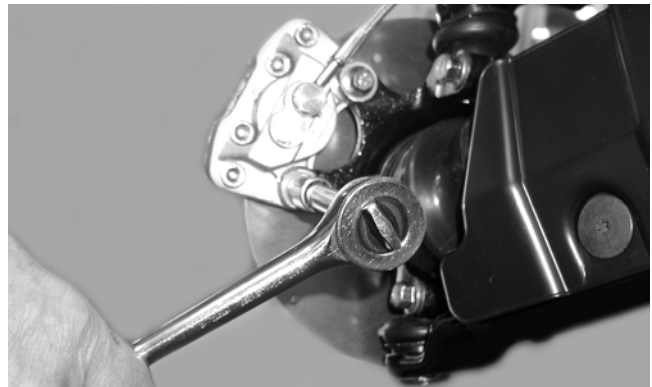

CD007

6. Tighten the hub nut (from step 4) to specifications; then install and spread a new cotter pin making sure each side of the pin is flush to the hub nut.



CD008

7. Install the wheel and tighten to specifications.



CD006

8. Remove the ATV from the support stand.

## Hydraulic Brake Caliper

■ **NOTE:** The brake caliper is a non-serviceable component; it must be replaced as an assembly.

### REMOVING/DISASSEMBLING

1. Secure the ATV on a support stand to elevate the wheel; then remove the wheel.

**⚠ WARNING**  
**Make sure the ATV is solidly supported on the support stand to avoid injury.**

2. Drain the brake fluid from the entire hydraulic system (reservoir, hoses, and caliper).



AF637D

**⚠ CAUTION**  
**Brake fluid is highly corrosive. Do not spill brake fluid on any surface of the ATV and do not reuse brake fluid.**

3. Remove the brake hose from the caliper; then remove the caliper.



AF636D

### CLEANING AND INSPECTING

1. Clean all caliper components (except the brake pads) with parts-cleaning solvent.
2. Inspect the brake pads for damage and excessive wear.

■ **NOTE:** For measuring brake pads, see Section 2.

### ASSEMBLING/INSTALLING

1. Push the pistons into the caliper as far as they will go to allow clearance for the brake pads.

**⚠ CAUTION**  
**Care should be taken that the piston and cylinder are not scratched.**

2. Install the brake pads and secure with the pin and cotter pin.

**6**

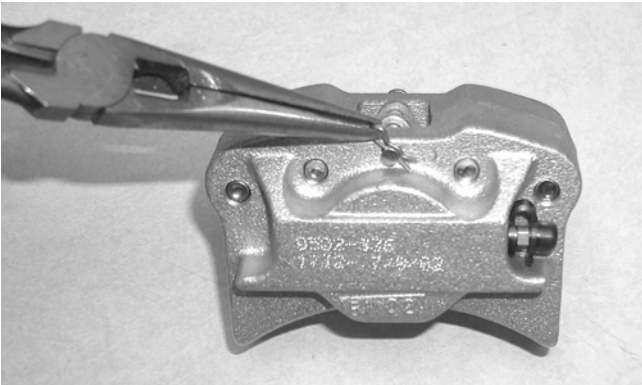

CD029

3. Place the brake caliper assembly into position and secure with the cap screws. Tighten the caliper to specifications.
4. Place a new crush washer on each side of the brake hose fitting and install it on the caliper. Tighten to specifications.
5. Fill the reservoir; then bleed the brake system (see Section 2).
6. Install the wheel. Tighten to specifications.



CD006

7. Remove the ATV from the support stand and verify brake operation.

# Hydraulic Brake Assembly Schematics

■ NOTE: Some components may vary from model to model. The technician should use discretion and sound judgment.

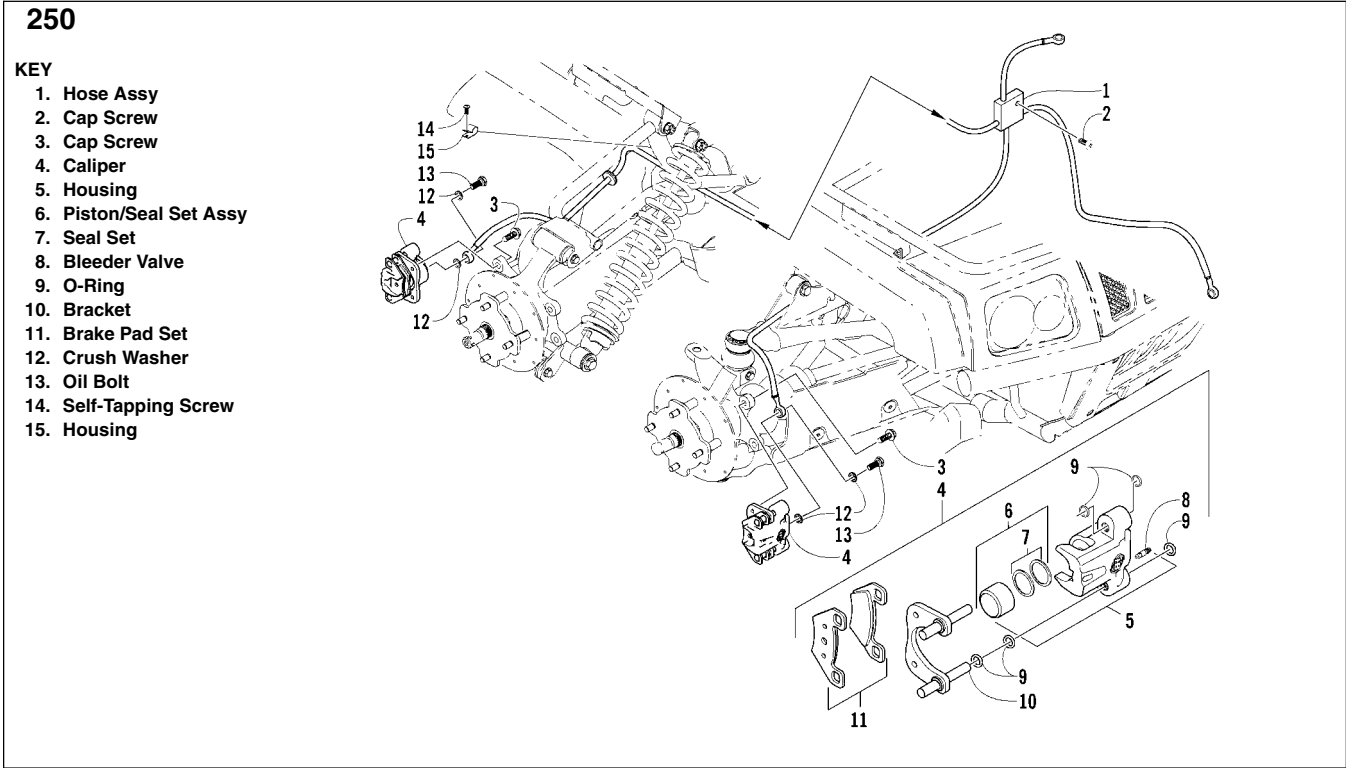

0739-480



### 300

KEY

- 1. Cap Screw
- 2. Hose - Front
- 3. Junction Block
- 4. Pressure Switch
- 5. Cap Screw
- 6. Caliper
- 7. Housing
- 8. Piston/Seal Set Assy
- 9. Seal Set
- 10. Bleeder Valve
- 11. O-Ring
- 12. Bracket
- 13. Brake Pad Set
- 14. Crush Washer
- 15. Oil Bolt
- 16. Tube
- 17. Clip
- 18. Hose
- 19. Machine Screw
- 20. Clamp

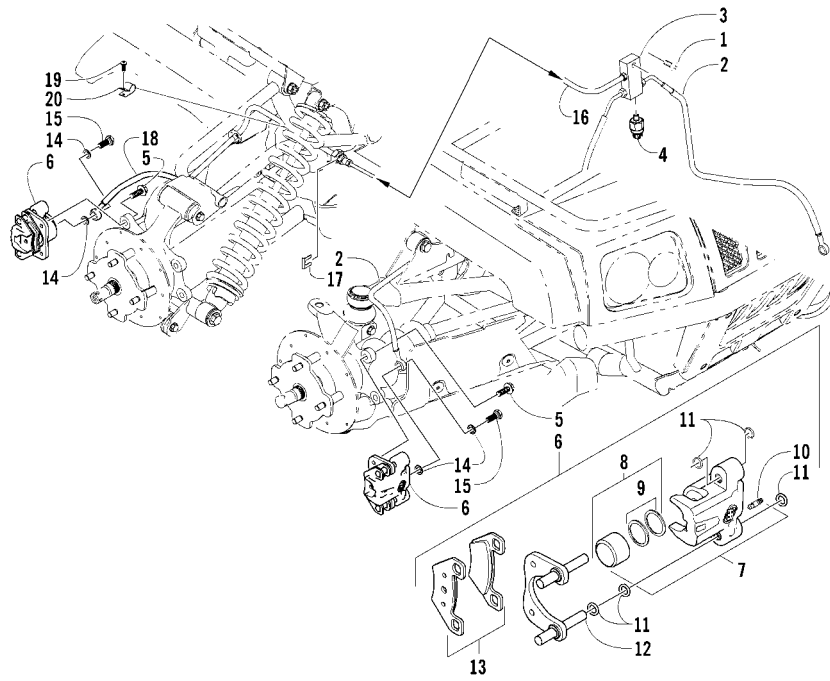

0739-469

### 400 FIS

KEY

- 1. Cap Screw
- 2. Hose
- 3. Junction Block
- 4. Plug
- 5. Cap Screw
- 6. Caliper
- 7. Housing
- 8. Piston/Seal Set Assy
- 9. Seal Set
- 10. Bleeder Valve
- 11. O-Ring
- 12. Bracket
- 13. Brake Pad Set
- 14. Crush Washer
- 15. Oil Bolt
- 16. Hose

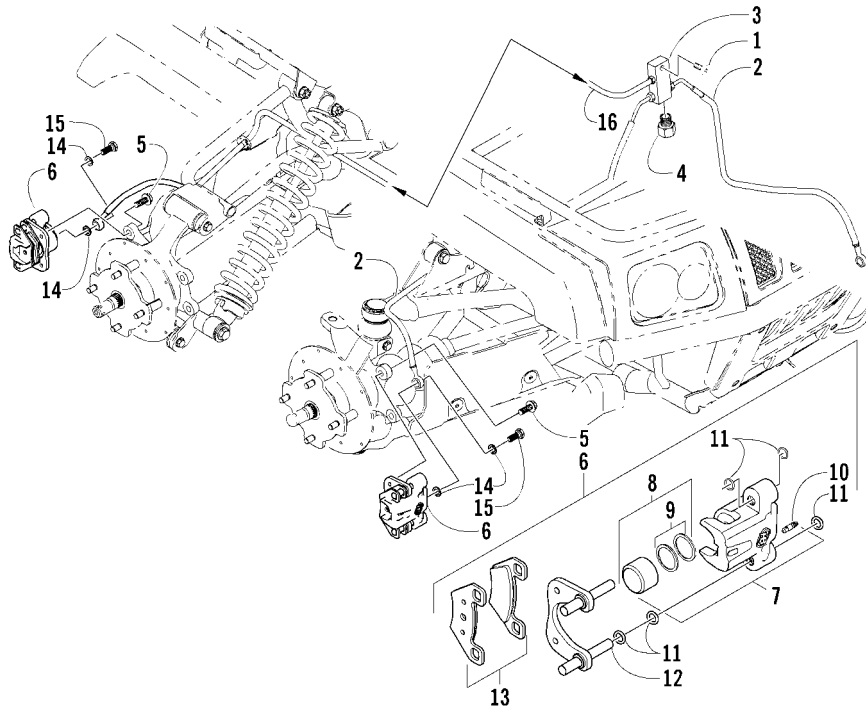

0739-253

### 400 ACT

KEY

- 1. Cap Screw
- 2. Front Hose
- 3. Junction Block
- 4. Oil Bolt
- 5. Crush Washer
- 6. Caliper Assy
- 7. Housing
- 8. O-Ring
- 9. Cotter Pin
- 10. Cap Screw
- 11. Bleeder Valve Cap
- 12. Brake Pad
- 13. Bleeder Valve
- 14. O-Ring
- 15. Pin
- 16. Housing
- 17. Clip
- 18. Rear Tube
- 19. Cap Screw
- 20. Pressure Switch
- 21. Rear Hose

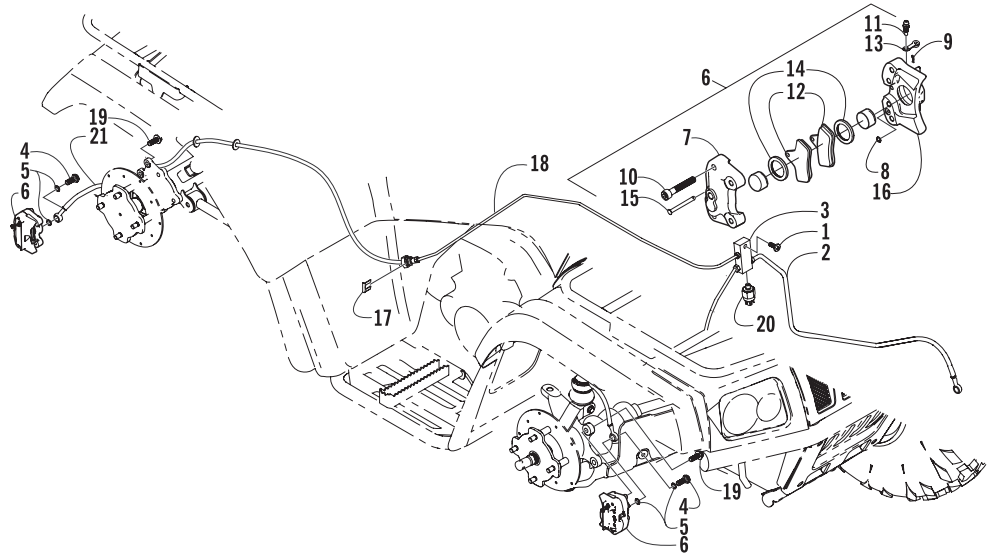

0737-568

### 500 FIS/TRV/650 V-Twin

KEY

- 1. Hose Assy
- 2. Cap Screw
- 3. Cap Screw
- 4. Caliper
- 5. Housing
- 6. Piston/Seal Set Assy
- 7. Seal Set
- 8. Bleeder Valve
- 9. O-Ring
- 10. Bracket
- 11. Brake Pad Set
- 12. Crush Washer
- 13. Oil Bolt

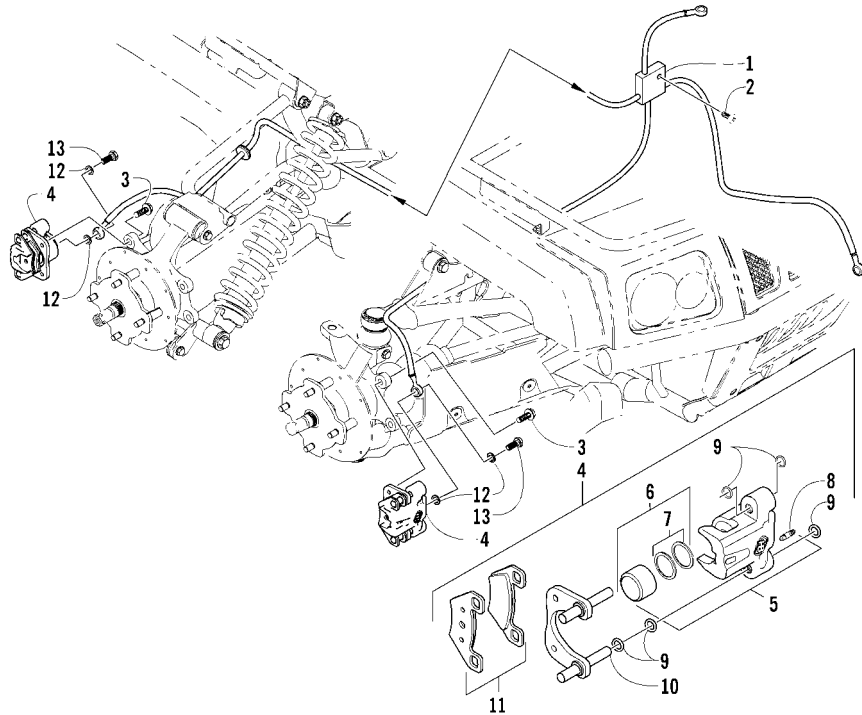

0739-796

### 650 V-Twin

KEY

- 1. Cap Screw
- 2. Hose - Front
- 3. Junction Block
- 4. Plug
- 5. Cap Screw
- 6. Caliper
- 7. Housing
- 8. Piston/Seal Set
- 9. Seal Set
- 10. Bleeder Valve
- 11. O-Ring
- 12. Bracket Assy
- 13. Brake Pad
- 14. Crush Washer
- 15. Oil Bolt
- 16. Hose - Rear

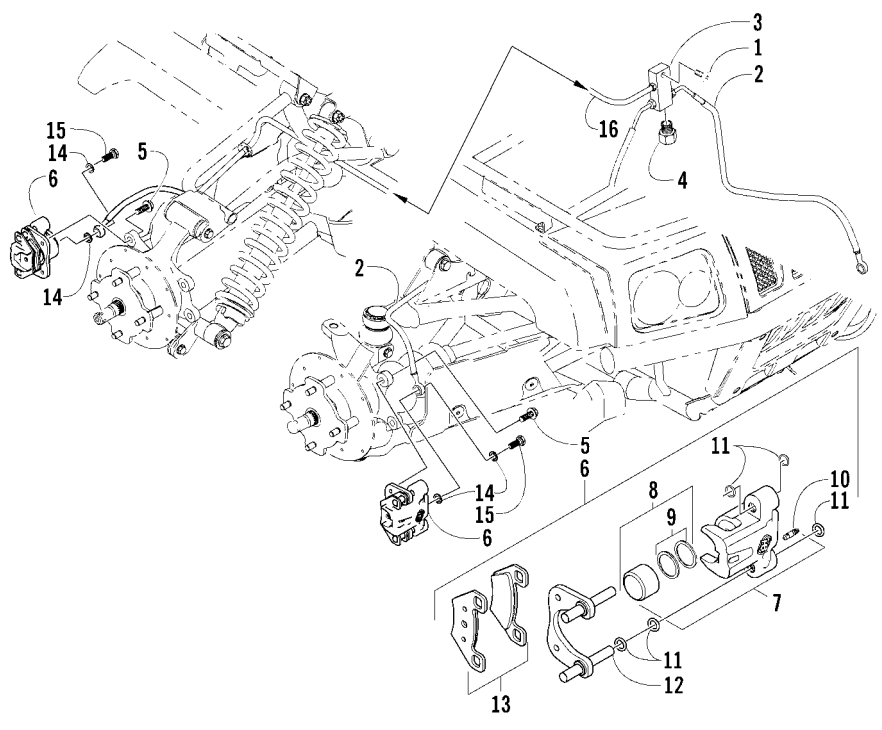

0739-253

# NOTES